



Planetary Drive

Section 03-03

Komatsu has made every effort to make this manual as accurate as possible based on the information available at the time of publication and printing. Continuous improvement and advancement of product design may cause changes to machines, which may not have been included in this publication. Komatsu reserves the right to make changes and improvements at any time. To ensure the most current information, please contact your service center.

Table of Contents

Scope of This Publication, 03-03	5
Customer Responsibilities and Warranty Advisories	5
Safety	7
Safety, Warnings, and Cautions	7
Additional Warnings and Cautions.....	10
Planetary Drive and Traction Motor Removal and Replacement Procedures	13
Planetary Drive Rotation.....	13
Traction Motor Maintenance and Repair	15
Determining the Need to Repair/Rebuild a Planetary Drive	17
Lubricating Oil Analysis	17
Removal of Planetary Drive and Traction Motor Assembly	19
Safety Preparations	21
Converter Bus Voltage.....	24
In Cab Verification Using LINCS II Display	25
Verification by Visual Indication.....	27
Verification by Physical Measurement Main Bus Bars	28
Converter Assembly Bus Connections	29
Removal.....	30
Shipping Motor to Rebuild Facility	37
Shipping a Planetary Drive to Rebuild Facility.....	38
Installation of Traction Drive Motor onto Planetary Drive	39
Safety Preparations	39
Installation.....	39
Installation of Traction Motor and Planetary Drive Assembly into Axle	49
Safety Preparations	50
Converter Bus Voltage.....	53
In Cab Verification Using LINCS II Display	54
Verification by Visual Indication.....	56
Verification by Physical Measurement Main Bus Bars	57
Converter Assembly Bus Connections	58
Installation.....	59
Servicing Requirements after Planetary Drive Repair or Replacement	61
Planetary Drive (Driver) General Lubrication Requirements	63
ISO Viscosity Grade	63
Lubricant Properties.....	63
Motors with Labyrinth Seal	64
Capscrew and Bolt-Nut Torque Specifications	67
Standard SAE G8 and Alloy Steel and Hex Socket Capscrews.....	68
Standard Metric Bolts and Grades (SAE J1701M)	69

Special Torque Specifications	70
Alloy Steel 12PT. Capscrew for Wheel Loader Lift Arm Ballcaps	70
Steering Pins (Hex Head Bolt).....	70
Aluminum 12pt. Capscrews used for Motor Pinion Balancing.....	70
2-Thread (2-Start) Steel 12PT. Capscrews	70
Bolt and Capscrew Markings on Head	70
Key Items.....	71

List of Figures

Figure 1.	51A2 and 57 Planetary drive rotation patterns (All GEN2 machines)	13
Figure 2.	Component weights	19
Figure 3.	Frame lock in locked position	21
Figure 4.	GEN 2 Battery Isolation Box – Battery isolation switch in OFF position with locks in place	22
Figure 5.	Hydraulic reservoir air valve handle UP	22
Figure 6.	Open air reservoir bleed valves.....	23
Figure 7.	Pressure bleed down valves.....	23
Figure 8.	Converter assembly bus LED's	24
Figure 9.	LINCS logging/monitoring menu access	25
Figure 10.	Remove channels	25
Figure 11.	Left hand scroll	26
Figure 12.	Bus voltage indication.....	26
Figure 13.	Isolation and control switch assembly	27
Figure 14.	Bus voltage LED array on SR control board.....	27
Figure 15.	Main bus bars	28
Figure 16.	Converter assembly bus connections (rear of cabinet)	29
Figure 17.	Converter assembly bus connections (front of cabinet)	29
Figure 18.	Crane attachment for removal of traction motor/planetary drive/assembly	30
Figure 19.	Lifting fixture (p/n 421-7253) for model 51A2 planetary drive	31
Figure 20.	Lifting fixture (p/n 421-7198) for model 57 planetary drive.....	31
Figure 21.	Jack bolts.....	32
Figure 22.	Hoisting assembly from axle.....	32
Figure 23.	Typical view inside axle (some models have a different brake actuator than shown in photograph)	33
Figure 24.	Planetary drive and traction motor positioned for motor removal.....	33
Figure 25.	Typical traction motor lifting fixture	34
Figure 26.	Blocking placed between planetary drive and traction motor for disconnection of oil return hose	35
Figure 27.	Disconnection of oil return hose	36
Figure 28.	Planetary drive following removal of traction motor.....	36
Figure 29.	Typical locking procedure for traction motor.....	37
Figure 30.	Planetary drive positioned for installation of traction motor.....	39
Figure 31.	Location of top of planetary drive for installation of traction motor	40
Figure 32.	Traction motor lifting fixture	40
Figure 33.	O-ring between planetary drive and drive motor location.....	41
Figure 34.	R4150226 - Proper Type of Silicone for Motor and Driver Assembly	41
Figure 35.	Cut sealant cartridge nozzle to make small bead of sealant	42
Figure 36.	Examples of Yellow Warnings Associated with Motor Over-Temperature.....	43
Figure 37.	Correct application of silicone sealant	44
Figure 38.	O-ring installed with correct amount of sealant	44
Figure 39.	Positioning traction motor onto planetary drive	45
Figure 40.	Blocking placed between planetary drive and traction motor for connection of oil return hose	45
Figure 41.	Connection of oil return hose.....	46
Figure 42.	Apply sealant to all motor-to-planetary drive capscrew threads.....	46
Figure 43.	Install all motor-to-planetary drive capscrews	47
Figure 44.	Torquing of traction motor retaining capscrews (typical torquing operation).....	47
Figure 45.	Marking traction motor retaining bolts to indicate torquing.....	48
Figure 46.	Hydraulic reservoir air valve handle UP	51
Figure 47.	Pressure bleed down valves.....	52

Figure 48. Converter assembly bus LED's53
 Figure 49. Isolation and control switch assembly56
 Figure 50. Bus voltage LED array on SR control board.....56
 Figure 51. Main bus bars57
 Figure 52. Converter assembly bus connections (rear of cabinet)58
 Figure 53. Converter assembly bus connections (front of cabinet)58
 Figure 54. Hoisting assembly into axle59
 Figure 55. Verify correct lubricant level (45 planetary drive shown)64
 Figure 56. Incorrect Oil level (too high) (45 planetary drive shown)64
 Figure 57. Machine stationary on very steep side slope with oil over labyrinth seal (45 planetary drive shown)65
 Figure 58. Defective filtration pump (45 planetary drive shown)65
 Figure 59. Normal oil movement through labyrinth (45 planetary drive shown)66
 Figure 60. One outlet – on outside of endbell (45 planetary drive shown)66

List of Tables

Table 1. Service reference chart for planetary drive models 51A2, and 5761
 Table 2. Planetary drive capacities.....63
 Table 3. Planetary drive lubricant viscosity grade63
 Table 4. Planetary drive lubrication properties63

This Page Intentionally Left Blank

Scope of This Publication, 03-03

PLANETARY DRIVE contains **ESSENTIAL** information for owners, maintenance personnel, and operators, for operation, removal, replacement, and maintenance requirements for planetary drives and drive motors. It is **ESSENTIAL** for all personnel associated with the machine to become familiar with this information and the instructions contained in the other publications in this manual **BEFORE** operating the machine or performing any procedures on a planetary drive/motor assembly.

This publication is provided to assist technicians in the diagnostics, minor repair, removal, and installation of the traction motors and planetary drives as part of recommended preventive maintenance procedures or in the event of the need to rebuild.

Customer Responsibilities and Warranty Advisories

P&H wheel loaders are warranted in accordance with the warranty policy provided with the machine. The recommended operating and maintenance procedures set forth shall be followed to ensure warranty coverage is not jeopardized. Failure to comply with recommended operating and maintenance procedures may void machine warranty.

Any questions or problems relating to warranty policy or administration should be directed to Komatsu Service Center. Include the model and serial number, in-service date of the machine, and hour meter reading. **We especially draw your attention to the following safety advisories.**

CAUTION

If the machine is within the warranty period, traction motor or planetary drive repairs should be referred to a Komatsu Distributor. Service, repair or disassembly of the motor or planetary drive beyond the instructions contained in this publication could adversely affect the warranty.

NOTICE

Following the warranty period, it is recommended that major motor or planetary drive repair or component replacement be performed by a Komatsu authorized Service Center or rebuild center (as required by the extent of needed repair). Therefore, instructions for disassembly and reassembly of the motor and planetary drive are not provided herein. Distribution of instructions for customer disassembly and assembly of the motor and planetary drive for major repair or component replacement is administered by the Komatsu Product Support Group, in Longview, Texas, USA.

This Page Intentionally Left Blank

Safety

This publication contains special instructions that pertain to safety, operation, maintenance, and repair of the machine. Listed below are the signal words and symbols that precede these instructions and their meanings:

DANGER

- The danger label indicates a hazardous situation which, if not avoided, will result in death or serious injury.

WARNING

- The warning label indicates a hazardous situation which, if not avoided, could result in death or serious injury.

CAUTION

- The caution label, used with the safety alert symbol indicates a hazardous situation which, if not avoided, could result in minor or moderate injury (includes the safety alert symbol .

CAUTION

- The caution label (without safety alert symbol) is used to address practices not related to personal injury – only equipment damage.

NOTICE

The NOTICE graphic is to indicate areas of importance to the reader that are not related to personal injury or machine damage.

It is **ESSENTIAL** for operators and maintenance personnel to read and understand all of this publication prior to operating or performing maintenance/repair procedures to the machine.

Safety, Warnings, and Cautions

WARNING

CRUSH HAZARD

- Crush hazard exists when jacking up (raising) the machine. Components can fall. Always provide adequate hoists, lifting devices, and facilities to jack up the machine when removing and installing the traction motor and planetary drive assembly. Failure to provide adequate hoists, lifting devices, and facilities when removing or installing the drive motor and planetary drives can cause crush hazards resulting in serious injury or death.
- Crush hazards exist if the machine is started or moved while work processes are being performed on the machine. Place bucket flat and level on the ground. Place frame lock in the locked position and lock out the machine's starting capability before performing any work process. Follow all applicable lockout procedures and local rules and regulations for performing work processes. ANYONE performing inspections or service procedures to the machine should be familiar with ALL instructions and procedures contained in the machine's SERVICE MANUAL. Crush hazard

could occur if the machine is started or moves while any type of work process is being conducted on the machine, resulting in serious injury or death.

- Crush hazards exist in machine pivot area and area between the tires. Do not enter these areas unless it is verified that the operator has control over the steering and that personnel locking the frame lock have good communication with the operator. Entering the pivot area and area between the tires while the machine is moving or pivoting (articulating) could cause crush hazards resulting in serious injury or death.
- Crush hazards exist if all personnel are not cleared from the bucket and lift arm area before using the hydraulic hoist and bucket hydraulic pressure bleed down valves to relieve pressure from the hoist and bucket circuit. Clear all personnel from the area around the bucket and lift arms before operating hydraulic hoist and bucket hydraulic pressure bleed down valves. Using the hydraulic bleed down valves could result in some movement of the lift arms and bucket which could cause a crush hazard resulting serious injury or death.
- Crush hazard exists when removing bolts holding tire. Bolts can break causing uncontrolled movement of the tire. It is critically important to follow the proper torque sequence when removing a tire and wheel from the loader. Failure to do so could result in retaining bolt breakage and unplanned movement of the tire and rim, which could cause crush hazards resulting in serious injury or death.
- Crush hazard exists when using motor hoisting fixture. Fixture can break and component can fall if attempting to lift too much weight. Motor hoisting fixtures are for lifting motor only Lifting the motor and planetary drive can cause crush hazards resulting in serious injury or death.
- Crush hazard exists when separating the motor from the planetary drive. Planetary drive models 57, 51A2, have an internal planetary drive filtration hose connecting the planetary drive to the motor. On all planetary drives, ensure the hose is disconnected prior to separating the planetary drive from the motor. Failure to ensure the hose is disconnected can cause the planetary drive to tip over when the motor is lifted. Failure to disconnect the hose can cause crush hazards resulting in serious injury or death.
- Crush hazards exist if standing under, or placing any body part under hoisted/suspended components. Never stand under hoisted/suspended components. Ensure appropriate lifting devices are used, and blocking is adequate to prevent the component from unexpectedly moving during transportation. Refer to SAFETY, WARNINGS, AND CAUTIONS before attempting to remove the operator's cab. Failure to stay out from under hoisted/suspended components can cause crush hazard resulting in serious injury or death.
- Crush hazards exist if attempting to lift the machine with the lift arms or bucket. Failure in the hydraulic pressure system can result in pressure loss which could cause the machine to descend rapidly. Always use adequate jacks, cranes or other equipment and adequate methods when lifting the machine. Failure to use adequate lifting equipment and methods can cause a crush hazard resulting in serious injury or death.

CRUSH, SHOCK, OR OTHER HAZARDS

- Crush, shock, or other hazards exist if stored energy is not removed or isolated prior to working on the machine. Stored energy (hydraulic, electrical, pneumatic, mechanical, etc.) may be present if not isolated or released prior to working on the machine. Do not work on the machine without removing this stored energy (suspended loads, electrical power, air pressure, etc.). Risk of crushing, shock, or other physical injury exists if stored energy is not removed or isolated prior to working on the machine which could result in serious injury or death.

ELECTRICAL SHOCK HAZARD

- Electrical shock hazard exists inside the axle if axle access panel on either axle is removed without locking out the electrical system. Always verify the absence of bus voltage before removing the axle access panels and touching any electrified component inside the axle. Failure to lockout the electrical system, and touching electrified components inside the axle could cause electrical shock which might result in serious injury or death.

- Electrical shock hazard exists when there is voltage on the bus. Do not touch any high voltage leads, connections, or components (including braking grids) until five minutes after the machine engine has been turned off and the absence of bus voltage is verified. It is possible for high voltage to be present for five minutes after the machine engine, on some models, has been turned off. Touching energized high voltage leads, connections, or components can cause electrical shock resulting in serious injury or death.
- Risk of fatal electrical shock or injury by contact in the electrical cabinet is possible if the engine is running, the LINC software indicates voltage on the bus, or the red bus LED's in the electrical cabinet are illuminated. All Generation II SR equipment has the ability to produce voltage at low throttle. Even with the engine off, there may be a residual of 12-15VDC on the bus. Do not enter the electrical cabinet or touch any components in the electrical cabinet without performing the Bus Discharge Verification Procedure. Failure to do so may result in fatal electrical shock or other injury.
- High voltage may be present. Risk of shock or equipment damage by use of an improperly rated meter is possible. Use a CAT III 1000V rated volt meter to take voltage readings.
- Electrical shock hazards exist inside the axle if touching electrical connections inside the axle without verifying the absence of bus voltage. NEVER touch electrical lead connections unless the machine's electrical system has been turned off and locked out, and the absence of bus voltage is verified. Contact with energized terminals inside the axle could cause electrical shock resulting in serious injury or death.

EXPLOSION HAZARD

- Explosion hazard exists if handling fully inflated tires. Bleed the tire air pressure to "0" psi/bar before handling a tire. No fully inflated tire should be handled. Failure to bleed the tire pressure to "0" can result in explosion resulting in serious injury or death.

CAUTION

CRUSH HAZARD

- Crush hazard exists when separating the planetary drive and drive motor. Lift the motor slowly, to ensure the seal between them releases before applying enough lifting force with the lifting device to raise both the planetary drive and the motor. The lifting fixtures previously bolted to the side of the motor are not rated to lift the weight of both the planetary drive and the motor. Applying too much pressure can break the attaching bolts. Breaking the bolts of the lifting device will cause uncontrolled movement of the lifting device, straps, chains, or other lifting components used during lifting. Lifting the motor too far can cause a crush hazard resulting in personal injury.

PINCH POINT HAZARDS

- Pinch point hazards exist when routing the hoses inside the axle. Never place any body part against a solid, un-moveable component surface when the motor is being installed inside the axle. Inspect the inside axle area for pinch points before installing the motor and planetary drive assembly. Close attention is required to avoid potential body pinch points when routing hoses inside the axle during planetary drive/motor installation. Direct communication between the crane operator and installer and expert control of the crane are required. Failure to inspect inside the axle for pinch points, and to have good communications between the crane operator and the installer can result in pinch points resulting in personal injury.

Additional Warnings and Cautions

Component Weights			
Component	Vehicle Type	Lb.	Kgs.
SR Motors	B40A (L-1350)	3,700	1,679
	B60 (L-1850-L-2350)	5,700	2,586
Planetary Drives	51A2 Planetary Drive (L-1350)	9,200	4,174
	57 Planetary Drive (L-1850-L-2350)	15,500	7,031
Tire & Wheel	L-1350	11,000	4,989
	L-1850	17,000	7,711
	L-2350	22,000	9,979
Motor, Planetary Drive and Brake Assembly	51A2 Planetary Drive, B40A Motor, Brake	13,000	6,532
	57 Planetary Drive, B60 Motor, Brake	21,200	9,617
	57 Planetary Drive, B60 Motor, Brake	21,200	9,617

WARNING

Struck by and struck against hazards exist when assembling, disassembling, or repairing brake actuator assemblies. Brake actuators contain very large springs capable of producing extreme force if improperly released. Never attempt to work on an actuator without reading and understanding all procedures for such work. Refer to **SERVICE BRAKE MAINTENANCE** (located in Service Manual) before attempting to disassemble or repair the air service brake. Releasing the spring inside the brake actuator improperly can cause struck by and struck against hazards causing serious injury or death.

CAUTION

Planetary drive models 57 and 51A2 have an internal planetary drive filtration hose connecting the planetary drive to the motor. On all planetary drives, ensure the hose is disconnected prior to separating the planetary drive from the motor. Failure to disconnect the hose can cause equipment damage.

CAUTION

It is critically important to flush the planetary drive after the first 150 hours of operation. Refer to Service Manual for information about flushing the drive.

CAUTION

DO NOT attempt to lift the machine with the lift arms and its supporting members. Serious damage could occur.

CAUTION

Separate the planetary drive and drive motor slowly, to ensure the seal between them releases before applying enough lifting force with the lifting device to raise both the planetary drive and the motor. The lifting fixtures previously bolted to the side of the motor are not rated to lift the weight of both the planetary drive and the motor. Applying too much pressure can break the attaching bolts. Breaking the bolts of the lifting device will cause uncontrolled movement of the lifting device, straps, chains, or other lifting components used during lifting.

This Page Intentionally Left Blank

Planetary Drive and Traction Motor Removal and Replacement Procedures

Planetary Drive Rotation

All GEN2 machines with 51A2, and 57 planetary drives: Rotation of the traction motors and planetary drives are required every 10,000 hours as part of normal preventive maintenance procedures. Rotation patterns are shown below.

At each 20,000-hour rotation interval, it is recommended that each traction motor be removed from its planetary drive and the motor pinion and planetary drive internal gears be inspected. Inspection of middle pinion and countershaft gears requires draining the planetary drive and removing the cover structure. Instructions for removal of the traction motor from the planetary drive and installation of the traction motor onto the planetary drive are also provided.

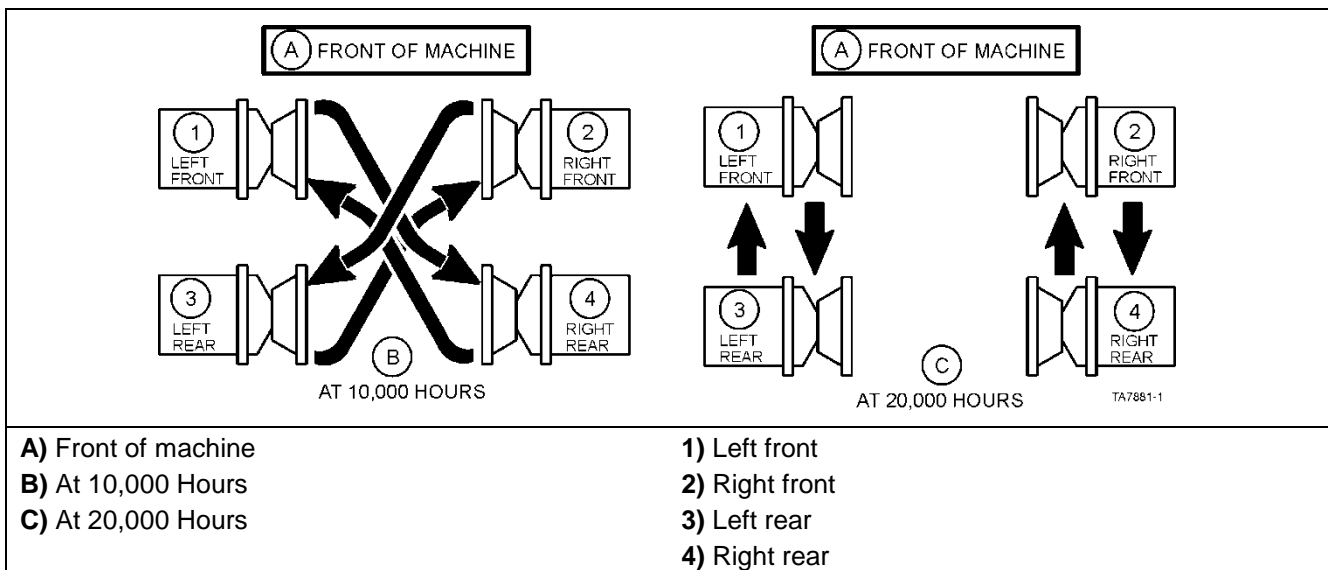

Figure 1. 51A2 and 57 Planetary drive rotation patterns (All GEN2 machines)

This Page Intentionally Left Blank

Traction Motor Maintenance and Repair

The traction motor requires no internal maintenance other than to inspect for planetary drive oil leaking into the internal components of the motor. Oil ingress into the motor can occur if the planetary drive is overfilled and/or a seal fails.

Traction motor repairs, including seal and bearing replacement, should be referred to a Komatsu authorized repair facility.

CAUTION

If the machine is within the warranty period, traction motor or planetary drive repairs should be referred to a Komatsu service center. Service, repair or disassembly of the motor or planetary drive beyond the instructions contained in this publication could adversely affect the warranty.

NOTICE

Following the warranty period, it is recommended that major motor or planetary drive repair or component replacement be performed by a Komatsu authorized Service Center or rebuild center (as required by the extent of needed repair).

This Page Intentionally Left Blank

Determining the Need to Repair/Rebuild a Planetary Drive

Lubricating Oil Analysis

Detecting impending failure of planetary drive components and taking immediate action to prevent catastrophic failure is the best means of lessening the expense of repair and unexpected downtime. This is best accomplished through an on-going lubricating oil analysis program. Establishing an on-going lubricating oil analysis program is covered in the Service Manual.

The decision to remove the planetary drive should be made if the results of lubricating oil analysis indicate a rapid rise in metal content between samples. This may indicate that wear trends are high and unacceptable and failure may be imminent.

Consulting with either the Komatsu rebuild center or the Komatsu distributor's engineering staff or directly with Komatsu Product Support is recommended prior to pulling the planetary drive.

NOTICE

If the machine is still under warranty, consult with the Komatsu Service Center in your area before removing the planetary drive from the machine.

This Page Intentionally Left Blank

Removal of Planetary Drive and Traction Motor Assembly

The traction motor and planetary drive are removed as an assembly. It is essential to provide adequate hoisting devices and be familiar with all aspects of the removal procedures before attempting to remove the assembly. It is also essential to provide adequate personnel to ensure the assembly is removed safely and no damage is done to the traction drive motor, brake components, hoses, and wiring during the removal. Should you need assistance with the removal beyond the instructions listed in this manual, contact your distributor.

WARNING

Crush hazard exists when jacking up (raising) the machine. Components can fall. Always provide adequate hoists, lifting devices, and facilities to jack up the machine when removing and installing the traction motor and planetary drive assembly. Failure to provide adequate hoists, lifting devices, and facilities when removing or installing the drive motor and planetary drives can cause crush hazards resulting in serious injury or death.

Component Weights			
Component	Vehicle Type	Lb.	Kgs.
SR Motors	B40A (L-1350)	3,700	1,679
	B60 (L-1850-L-2350)	5,700	2,586
Planetary Drives	51A2 Planetary Drive (L-1350)	9,200	4,174
	57 Planetary Drive (L-1850-L-2350)	15,500	7,031
Tire & Wheel	L-1350	11,000	4,989
	L-1850	17,000	7,711
	L-2350	22,000	9,979
Motor, Planetary Drive and Brake Assembly	51A2 Planetary Drive, B40A Motor, Brake	13,000	6,532
	57 Planetary Drive, B60 Motor, Brake	21,200	9,617

Figure 2. Component weights

CAUTION

DO NOT attempt to lift the loader with the lift arms and its supporting members. Serious damage to machine could occur.

 **WARNING**

Explosion hazard exists if handling fully inflated tires. Bleed the tire air pressure to “0” psi/bar before handling a tire. No fully inflated tire should be handled. Failure to bleed the tire pressure to “0” can result in explosion resulting in serious injury or death.

 **WARNING**

Electrical shock hazard exists inside the axle if axle access panel on either axle is removed without locking out the electrical system. Always verify the absence of bus voltage before removing the axle access panels and touching any electrified component inside the axle. Failure to lockout the electrical system, and touching electrified components inside the axle could cause electrical shock which might result in serious injury or death.

 **WARNING**

Electrical shock hazard exists when there is voltage on the bus. Do not touch any high voltage leads, connections, or components (including braking grids) until five minutes after the machine engine has been turned off and the absence of bus voltage is verified. It is possible for high voltage to be present for five minutes after the machine engine, on some models, has been turned off. Touching energized high voltage leads, connections, or components can cause electrical shock resulting in serious injury or death.

 **WARNING**

Crush hazards exist if attempting to lift the machine with the lift arms or bucket. Failure in the hydraulic pressure system can result in pressure loss which could cause the machine to descend rapidly. Always use adequate jacks, cranes or other equipment and adequate methods when lifting the machine. Failure to use adequate lifting equipment and methods can cause a crush hazard resulting in serious injury or death.

Safety Preparations

Use the following procedure to isolate energy sources before performing any removal, replacement, or installation procedures described in this document.

WARNING

Crush hazards exist if the machine is started or moved while work processes are being performed on the machine. Place bucket flat and level on the ground. Place frame lock in the locked position and lock out the machine's starting capability before performing any work process. Follow all applicable lockout procedures and local rules and regulations for performing work processes. ANYONE performing inspections or service procedures to the machine should be familiar with ALL instructions and procedures contained in the machine's SERVICE MANUAL. Crush hazard could occur if the machine is started or moves while any type of work process is being conducted on the machine, resulting in serious injury or death.

- a. Stop the wheel loader on flat level ground.
- b. Move the frame lock to the locked position so that the frame cannot be steered.

WARNING

Crush hazards exist in machine pivot area and area between the tires. Do not enter these areas unless it is verified that the operator has control over the steering and that personnel locking the frame lock have good communication with the operator. Entering the pivot area and area between the tires while the machine is moving or pivoting (articulating) could cause crush hazards resulting in serious injury or death.

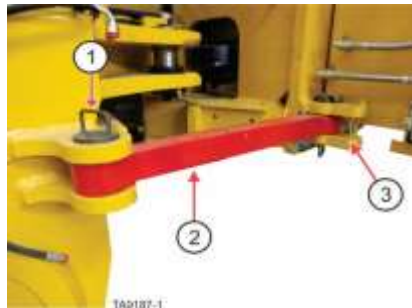

- 1) Retaining pin for locked position, 2) Frame lock - shown in locked position,
3) Retaining pin bracket for un-locked position

Figure 3. Frame lock in locked position

- c. Place wheel chocks in front and behind each wheel.
- d. Set bucket flat and level on the ground.
- e. Set the parking brakes.
- f. Shut off the engine.

⚠ WARNING

Crush, shock, or other hazards exist if stored energy is not removed or isolated prior to working on the machine. Stored energy (hydraulic, electrical, pneumatic, mechanical, etc.) may be present if not isolated or released prior to working on the machine. Do not work on the machine without removing this stored energy (suspended loads, electrical power, air pressure, etc.). Risk of crushing, shock, or other physical injury exists if stored energy is not removed or isolated prior to working on the machine which could result in serious injury or death.

- g. Turn the battery and engine isolation switches to the off position and install locks on the battery isolation switch.



Figure 4. GEN 2 Battery Isolation Box – Battery isolation switch in OFF position with locks in place

NOTICE

The GEN 2 battery and engine starter isolation box is shown in this document. GEN 1 machines will have a different type of switch and box. The lock out/tag out requirements are the same.

- h. Release the air from the hydraulic reservoir by using the hydraulic reservoir air valve (ball valve) on top of the reservoir. The supply line from main air system will be blocked and reservoir air will vent out the hose that runs down the outside of the hydraulic reservoir.
- Turn the handle to the up position as shown

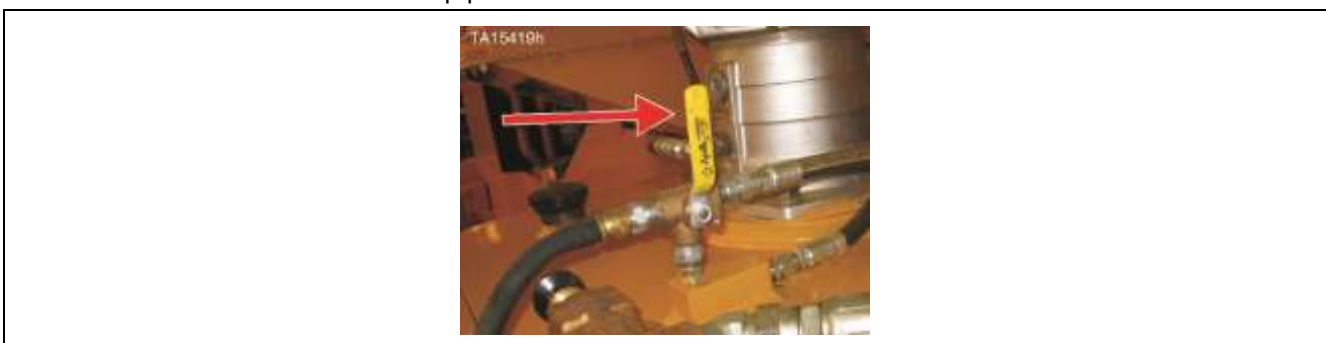

Figure 5. Hydraulic reservoir air valve handle UP

- i. Release the air from the various air storage reservoirs by opening all of the air bleed valves.

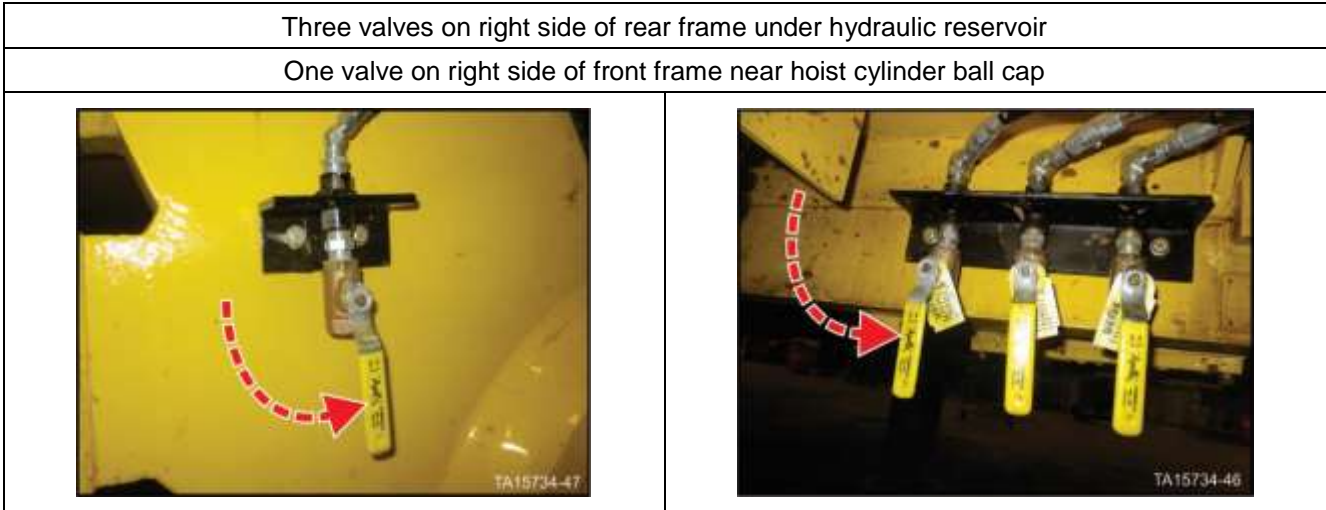

Figure 6. Open air reservoir bleed valves

 WARNING

Crush hazards exist if all personnel are not cleared from the bucket and lift arm area before using the hydraulic hoist and bucket hydraulic pressure bleed down valves to relieve pressure from the hoist and bucket circuit. Clear all personnel from the area around the bucket and lift arms before operating hydraulic hoist and bucket hydraulic pressure bleed down valves. Using the hydraulic bleed down valves could result in some movement of the lift arms and bucket which could cause a crush hazard resulting serious injury or death.

- j. Use the hydraulic pressure bleed down valves located in the front frame underneath the Husco valves to bleed any stored pressure in the hoist and bucket cylinders.
- k. Turn each valve slowly counterclockwise as shown below and allow the pressure to bleed down.
- l. Open the valve completely and leave it open during this procedure.



Figure 7. Pressure bleed down valves

Converter Bus Voltage

WARNING



Risk of fatal electrical shock or injury by contact in the electrical cabinet is possible if the engine is running, the LINC'S software indicates voltage on the bus, or the red bus LED's in the electrical cabinet are illuminated. All Generation II SR equipment has the ability to produce voltage at low throttle. Even with the engine off, there may be a residual of 12-15VDC on the bus. Do not enter the electrical cabinet or touch any components in the electrical cabinet without performing the Bus Discharge Verification Procedure. Failure to do so may result in fatal electrical shock or other injury.

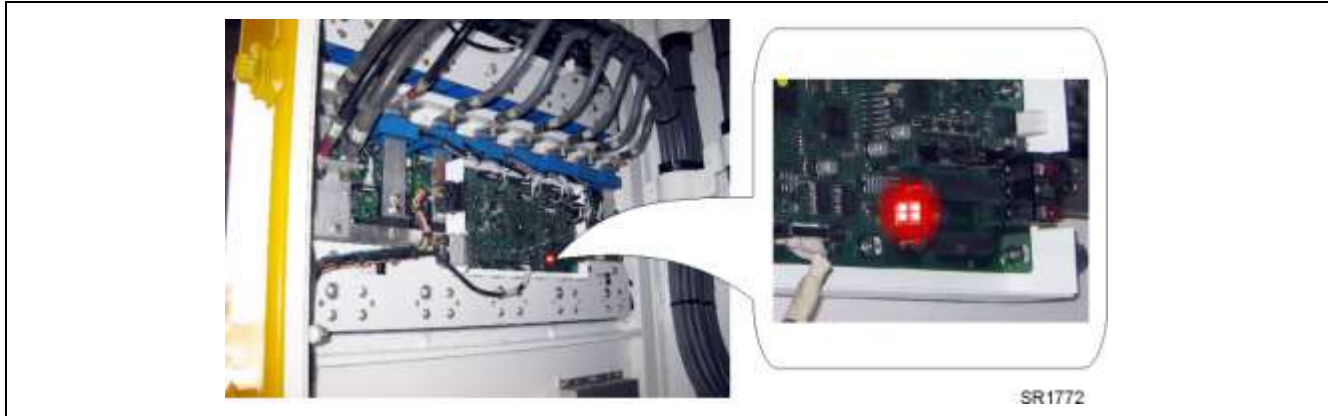

Figure 8. Converter assembly bus LED's

There are three different methods that are combined to verify when it is safe to enter the electrical cabinet.

1. LINC'S II display in cab
2. visual indication in electrical cabinet
3. physical measurement

All these steps are required to ensure the system is properly discharged.

In Cab Verification Using LINCS II Display

1. Make sure that the LINCS II system is booted (key switch ON) with the engine NOT running and the park brake SET.
2. As shown in the figure below, on the touch panel in the dash, press the Main Menu button in the lower left corner, then select Data Logging then Logging/Monitoring.

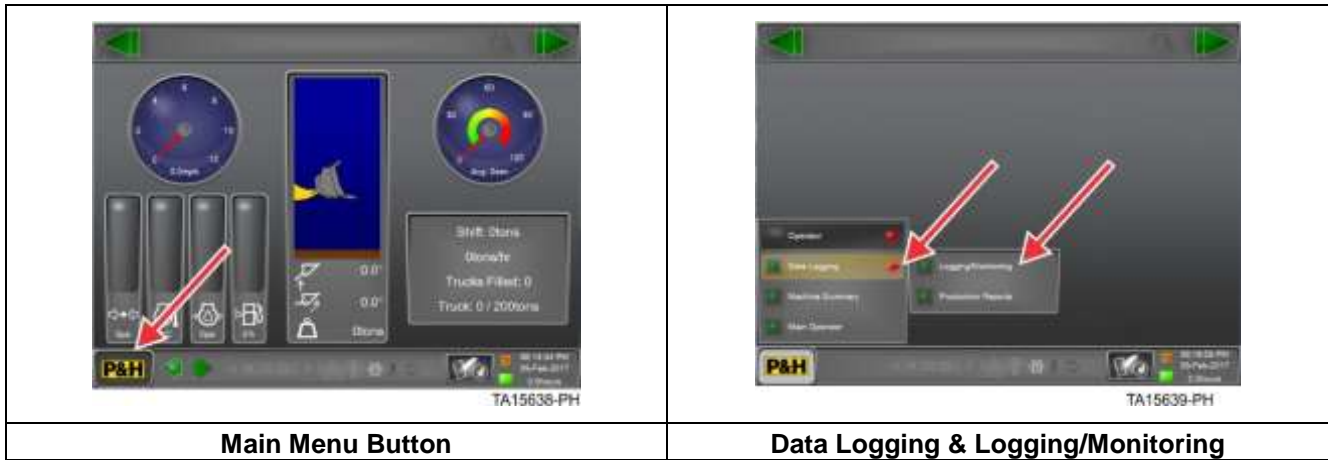

Figure 9. LINCS logging/monitoring menu access

3. Select the Trash Can icon and the select the Check Mark to clear any selection on the right hand side of the screen (if applicable).



Figure 10. Remove channels

4. Scroll down the left hand list until Drive Fuses is displayed.



Figure 11. Left hand scroll

5. Drag the Drive Fuses category to the right hand side of the screen, all of the bus voltage channels should now be visible.



Figure 12. Bus voltage indication

6. Verify bus voltage is less than 24VDC.

NOTICE

Should any voltage (greater than 24VDC) be present on any of the DC busses, allow the system to discharge for a period of no less than 10 minutes. Re-test the bus voltages prior to continuing.

7. Turn the key switch to the OFF position and proceed to the next step in the verification process.

Verification by Visual Indication

Following the verification by LINCS II software, the next step is to verify the existence of bus voltage by the array of four LED indicators located on the main SR control board on each converter assembly.

To conduct this test, ensure that:

- The 24VDC power is isolated at the battery disconnect (turned off and locked out) per site requirements.

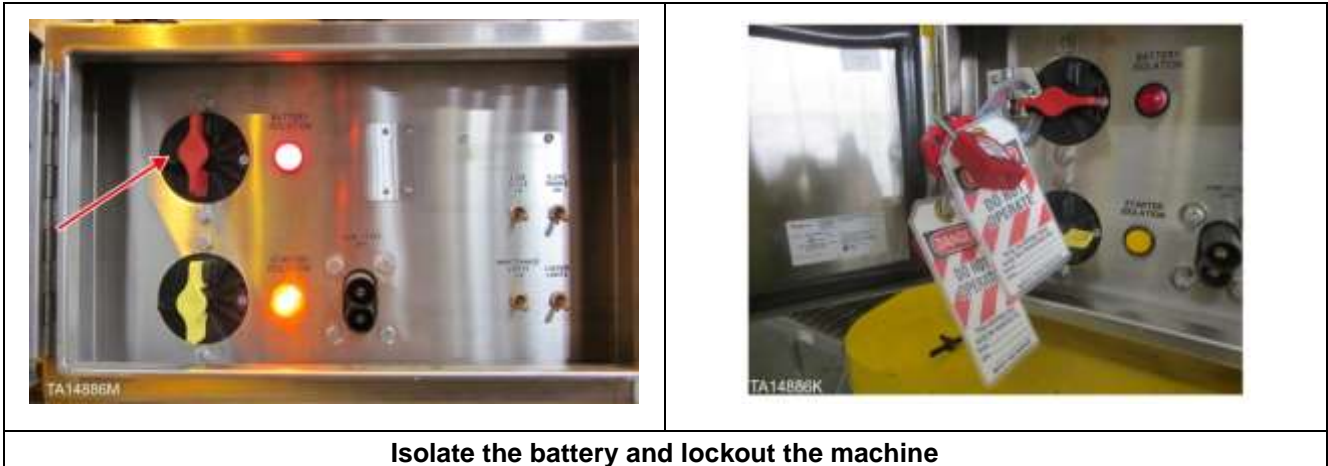

Isolate the battery and lockout the machine

Figure 13. Isolation and control switch assembly

- The SR electrical converter cabinet door should now be opened.
- DO NOT enter the cabinet at this time.

View the LED arrays on each of the converter assemblies and verify the LED's are not illuminated. The LED's will be illuminated when a potential of greater than approximately 35VDC is present on the DC bus connections on the converter assemblies. The light intensity varies with voltage and a greater intensity indicates a higher bus voltage.

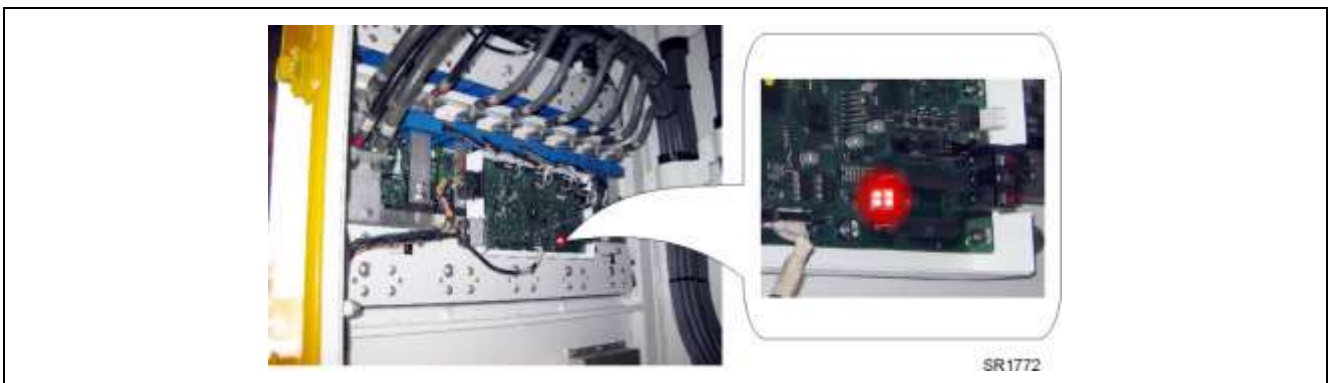

Figure 14. Bus voltage LED array on SR control board

Verification by Physical Measurement Main Bus Bars

Once the visual indicators have been verified, the bus voltage should be physically measured. The bus voltage should be fully discharged based on the previous checks.

- a. Measure between the positive and negative bus bars using a voltmeter rated for 1000V. The potential voltage on a bus that has not discharged could be over 700VDC. A properly discharged bus should be less than 24VDC as verified by the completion of LINCS system verification.

WARNING

High voltage may be present. Risk of shock or equipment damage by use of an improperly rated meter is possible. Use a CAT III 1000V rated volt meter to take voltage readings.

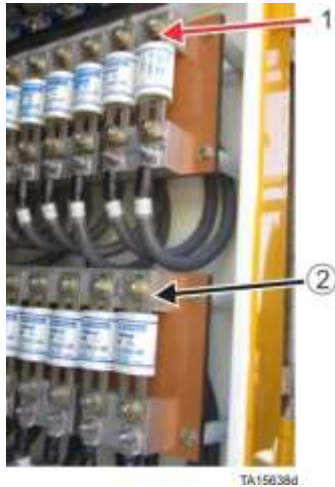

1) Positive bus bar, 2) Negative bus bar

Figure 15. Main bus bars

Converter Assembly Bus Connections

The final point of verification is the bus connections to each individual converter assembly. The bus voltage can be measured at the two bus tabs located adjacent to the electrical converter cabinet door.

NOTICE

The converter assemblies on the rear of the cabinet are inverted in comparison to those mounted on the front. Similarly, the positive and negative bus connections will be inverted.

Connect a voltmeter across the two bus connection points. Bus voltage should be less than 24VDC following the completion of the previous checks. Once the check has been completed, the entire drive system has been verified as discharged.



1) Positive bus bar, 2) Negative bus bar

Figure 16. Converter assembly bus connections (rear of cabinet)



1) Positive bus bar, 2) Negative bus bar

Figure 17. Converter assembly bus connections (front of cabinet)

Removal

- a. Use a suitable jack or crane to hoist machine sufficiently for removal of the wheel and tire. Refer to JACKING INSTRUCTIONS located in Service Manual.
- b. Remove the wheel and tire per the instructions in the Service Manual. Set wheel and tire aside until ready for reinstallation.

WARNING

Crush hazard exists when removing bolts holding tire. Bolts can break causing uncontrolled movement of the tire. It is critically important to follow the proper torque sequence when removing a tire and wheel from the loader. Failure to do so could result in retaining bolt breakage and unplanned movement of the tire and rim, which could cause crush hazards resulting in serious injury or death.

WARNING

Electrical shock hazard exists inside the axle if axle access panel on either axle is removed without locking out the electrical system. Always verify the absence of bus voltage before removing the axle access panels and touching any electrified component inside the axle. Failure to lockout the electrical system, and touching electrified components inside the axle could cause electrical shock which might result in serious injury or death.

- c. Remove the axle access covers.
- d. Disconnect and tag electrical leads from traction motor.
- e. Disconnect the planetary drive oil filtration hose attached to the motor endbell.
- f. Disconnect air lines from brake actuator.
- g. Attach lifting device to the planetary drive. To install the lifting device P/N 421-7211 to the Model 51A2 Planetary Drive.
 - Remove six capscrews that secure planetary drive to the axle (three on each side of the dowel pin at the top of the axle).
 - Release brake.
 - Install the lifting device. Use four of the capscrews removed to secure the lifting device against the flange where rim was previously mounted.



Figure 18. Crane attachment for removal of traction motor/planetary drive/assembly

- h. Attach crane to the lifting device with an adequate lifting clevis and support the planetary drive.

- i. Remove the remaining capscrews holding the planetary drive to axle.

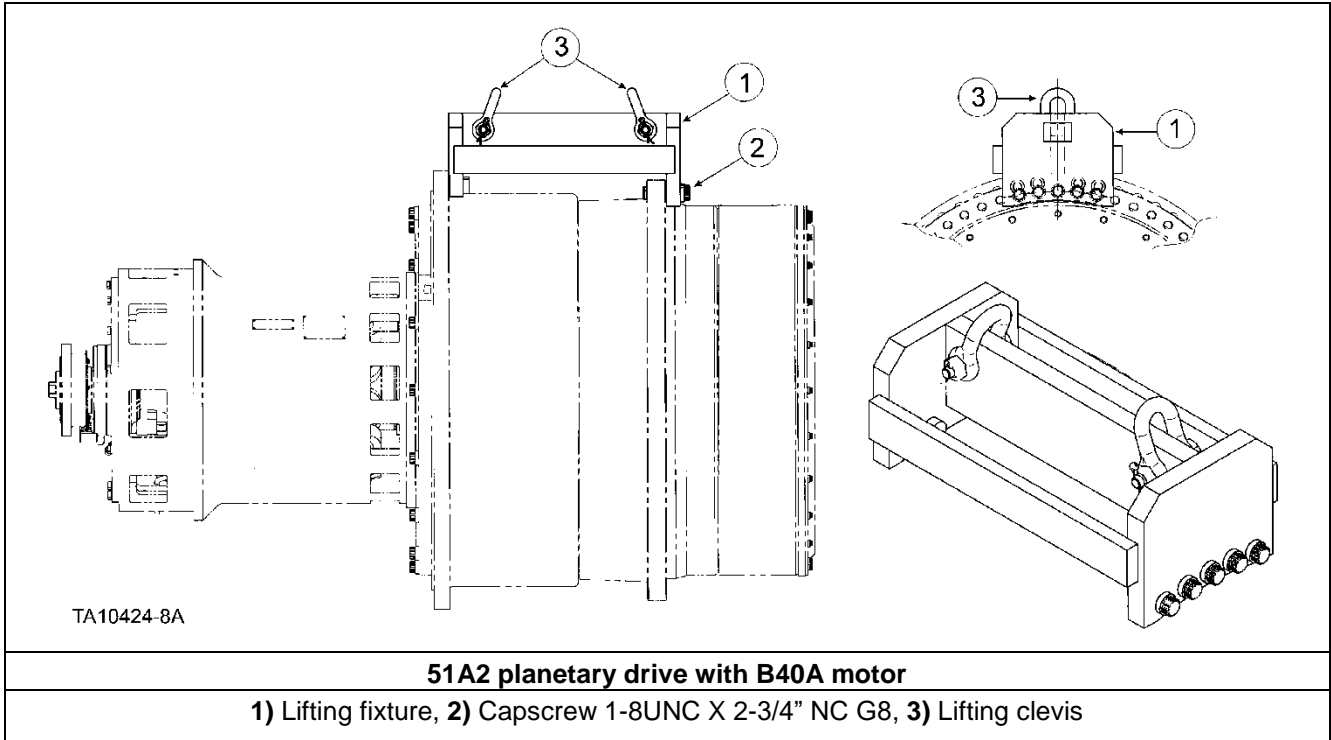

Figure 19. Lifting fixture (p/n 421-7253) for model 51A2 planetary drive

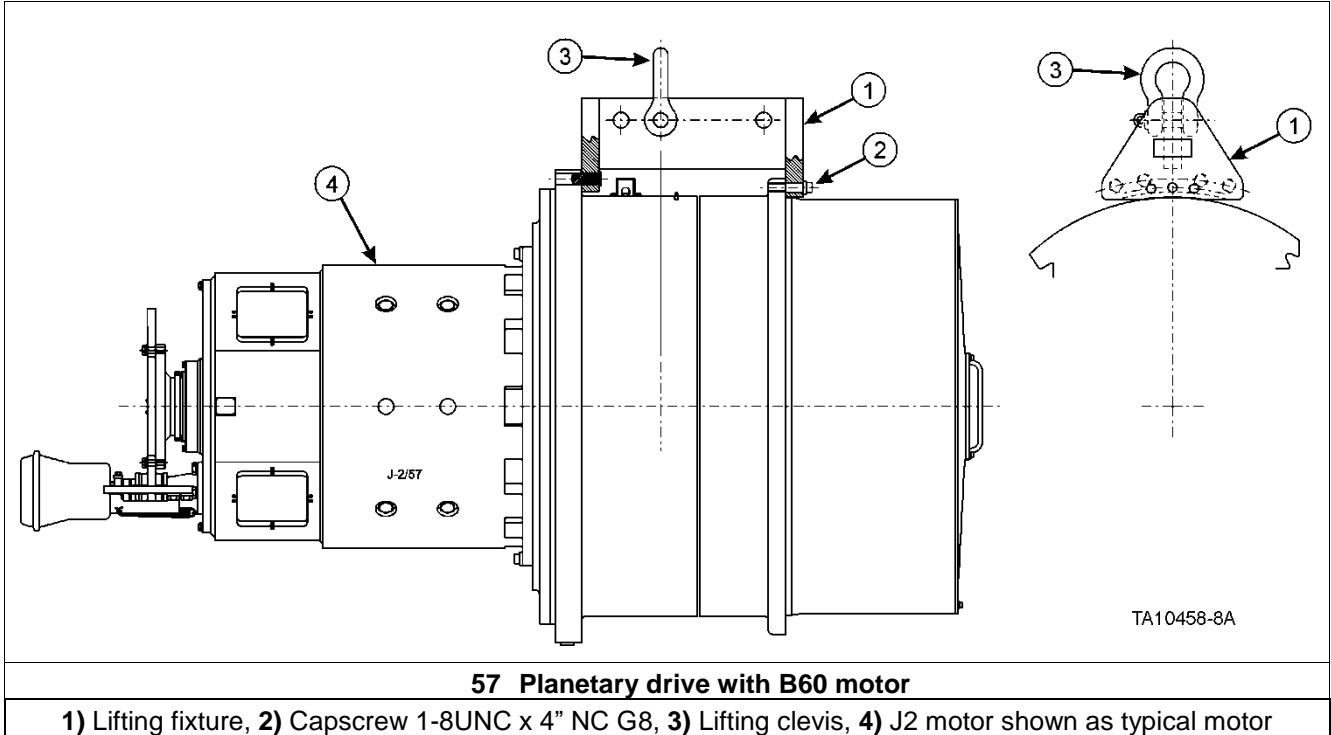
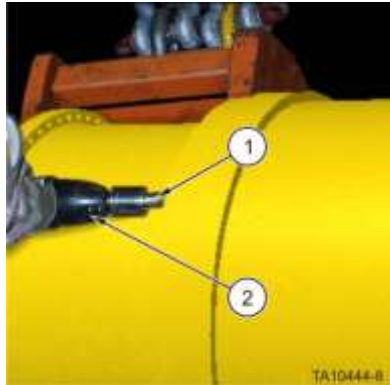

Figure 20. Lifting fixture (p/n 421-7198) for model 57 planetary drive

- j. Threaded holes for installation of capscrews to be used as jack bolts are provided on the planetary drive.
- **Planetary drive model 51A2:** Install 3/4"-10 NC capscrews into these holes to unseat the planetary drive from the axle.
 - **Planetary drive model 57:** Install 1-1/4"-12 UNF capscrews into these holes to unseat the planetary drive from the axle.

As they are installed, they will contact the axle to unseat the planetary drive and traction motor.



1) Jack bolt 2) 1" impact wrench

Figure 21. Jack bolts

- k. Hoist planetary drive and traction motor from axle. Keep assembly level during removal procedure.



Figure 22. Hoisting assembly from axle



Figure 23. Typical view inside axle (some models have a different brake actuator than shown in photograph)

CAUTION

As the assembly is hoisted from the axle, a technician should monitor the electrical lines and air hoses inside the axle to ensure none are damaged.

- I. Position planetary drive and traction motor onto wooden blocking with the traction motor up. Place blocking, such as a sturdy wooden pallet, to protect the planetary drive cover structure and bolts from damage due to contacting the floor.



Figure 24. Planetary drive and traction motor positioned for motor removal

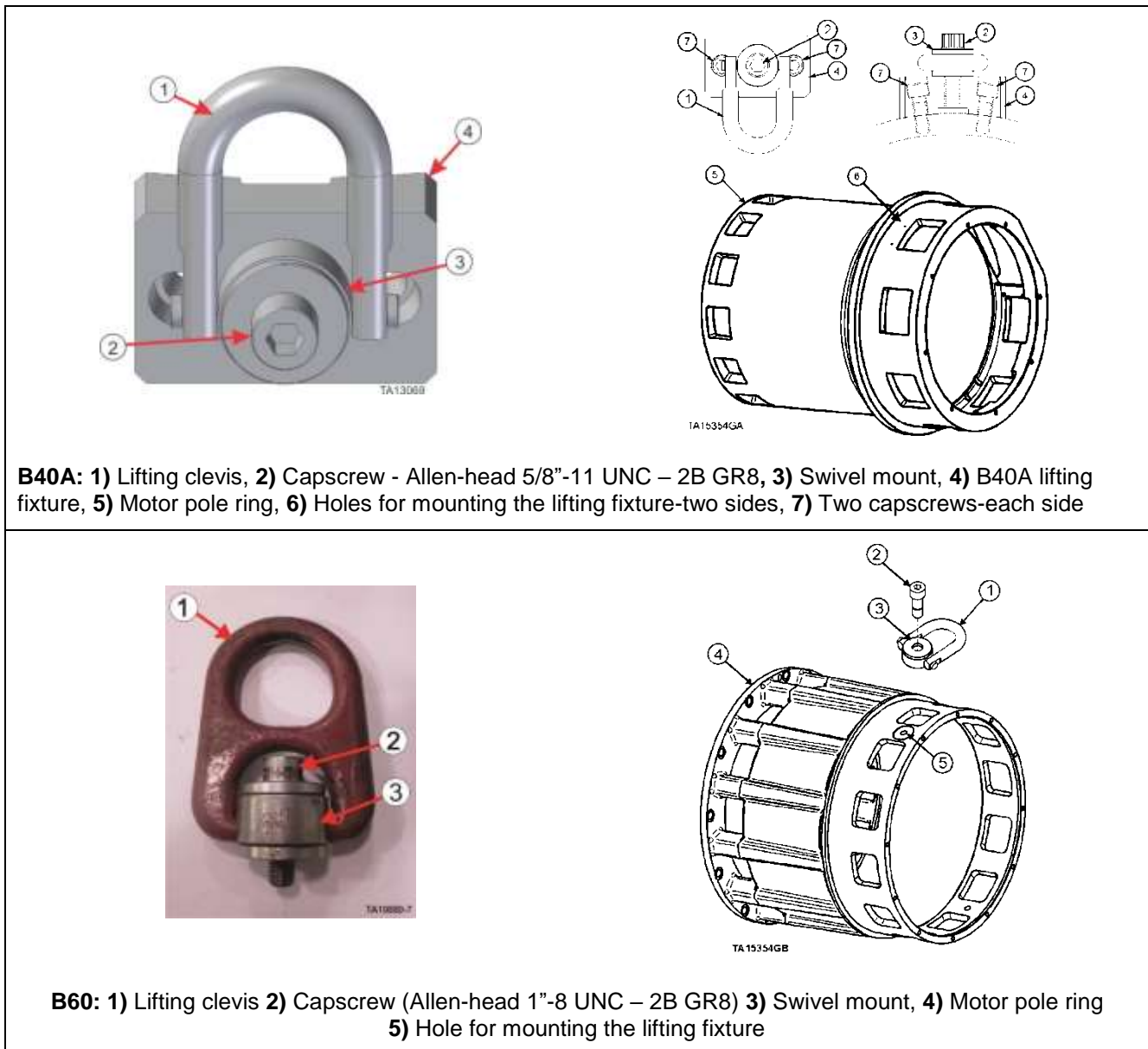

Figure 25. Typical traction motor lifting fixture

⚠ WARNING

Crush hazard exists when using motor hoisting fixture. Fixture can break and component can fall if attempting to lift too much weight. Motor hoisting fixtures are for lifting motor only! **NEVER** attempt to lift motor and planetary drive! Lifting the motor and planetary drive can cause crush hazards resulting in serious injury or death.

m. **B40A Motor:** Install lifting fixture 103-1519 to each side of B40A motor stator frame using 5/8"-11 UNC-2b-Grade 8 hex head bolts or alloy steel capscrews.

B60 Motor: Install commercially available swivel hoist ring (ref P/N 124-2807) rated at 10,000 lb. WLL (working load limit) to each side of B60 motor stator frame. Thread in the motor stator where the hoist ring attaches is 1"-8 UNC.

⚠ CAUTION

Crush hazard exists when separating the planetary drive and drive motor. Lift the motor slowly, to ensure the seal between them releases before applying enough lifting force with the lifting device to raise both the planetary drive and the motor. The lifting fixtures previously bolted to the side of the motor are not rated to lift the weight of both the planetary drive and the motor. Applying too much pressure can break the attaching bolts. Breaking the bolts of the lifting device will cause uncontrolled movement of the lifting device, straps, chains, or other lifting components used during lifting. Lifting the motor too far can cause a crush hazard resulting in personal injury.

- n. Remove capscrews which secure traction motor to planetary drive, then hoist traction motor from planetary drive 8" to 10" (203.2 mm to 254 mm).
- o. Place protective blocking between the motor and planetary drive as shown.



Figure 26. Blocking placed between planetary drive and traction motor for disconnection of oil return hose

- p. Disconnect the oil return hose, inside the planetary drive primary gear box, from the motor endbell.

⚠ CAUTION

Crush hazard exists when separating the motor from the planetary drive. Planetary drive models 57, 51A2 have an internal planetary drive filtration hose connecting the planetary drive to the motor. On all planetary drives, ensure the hose is disconnected prior to separating the planetary drive from the motor. Failure to ensure the hose is disconnected can cause the planetary drive to tip over when the motor is lifted. Failure to disconnect the hose can cause crush hazards resulting in serious injury or death.

CAUTION

Planetary drive models 57 and 51A2 have an internal planetary drive filtration hose connecting the planetary drive to the motor. On all planetary drives, ensure the hose is disconnected prior to separating the planetary drive from the motor. Failure to disconnect the hose can cause equipment damage.



Figure 27. Disconnection of oil return hose

- q. Place traction motor onto blocking as shown below.
- r. Cover planetary drive spindle, following removal of traction motor, to ensure that no dirt or debris enters the planetary drive.

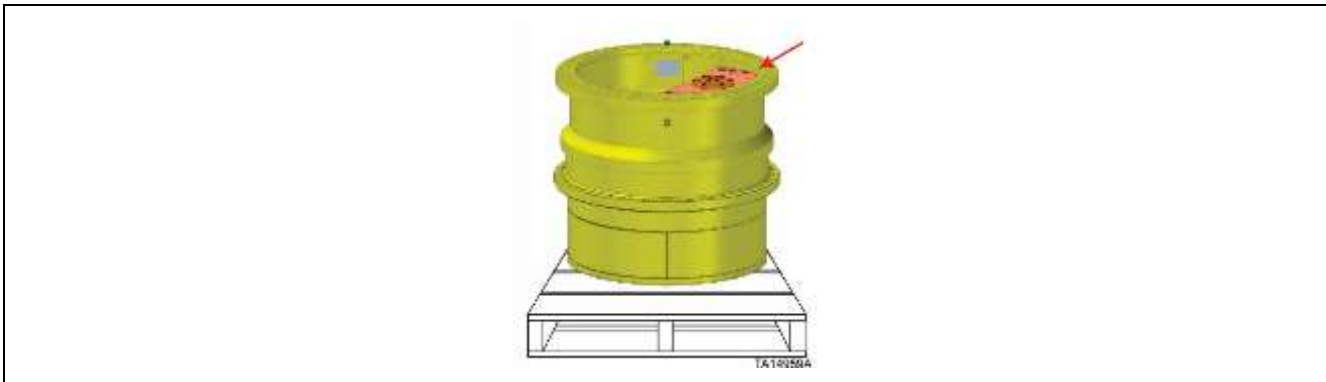

Figure 28. Planetary drive following removal of traction motor

Shipping Motor to Rebuild Facility

- a. Remove disc brake rotor and caliper assembly per the instructions in DISC PAD REPLACEMENT. Do not remove the brake hub. The brake hub must be sent to the Rebuild Center with the motor as it is an important part of assembly and testing procedures.
- b. Remove motor seal ring.
- c. Hoist the motor onto a shipping pallet and remove hoisting device.
- d. Lock armature shaft to prevent bearing brinelling damage during shipment (caused by excessive vibration). Lock the armature with studs and nuts or bolts (of the appropriate size and length for your application) between the brake hubs and endbell. The fasteners should only be tightened enough to remove the end play from the bearing.
- e. Secure motor onto pallet with metal banding and then construct a plywood box around the motor.

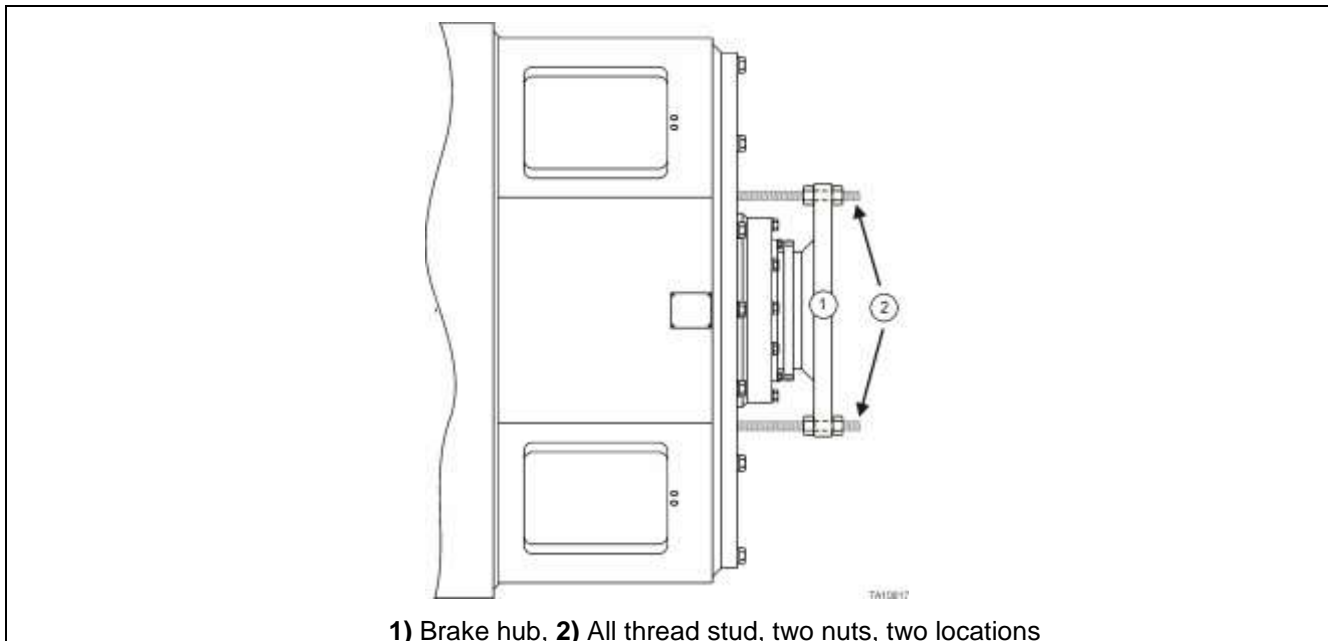

Figure 29. Typical locking procedure for traction motor

Shipping a Planetary Drive to Rebuild Facility

- a. Drain planetary drive if not drained prior to removal. DO NOT ship the planetary drive to rebuild facility full of oil. Dispose of oil in a proper manner.
- b. Place a protective plywood cover over the open spindle structure and secure with bolts or metal banding.
- c. Hoist the planetary drive onto a suitable shipping pallet and secure with metal banding. Construct a sturdy plywood box around the planetary drive and secure the box to the pallet.

Installation of Traction Drive Motor onto Planetary Drive

The traction motor and planetary drive are installed as an assembly. It is essential to provide adequate hoisting devices and be familiar with all aspects of the installation procedures before attempting to install the assembly. It is also essential to provide adequate personnel to ensure the assembly is installed safely and no damage is done to the traction drive motor, brake components, hoses and wiring during the installation. Should you need assistance with the installation beyond the instructions listed in this manual, contact your distributor.

WARNING

Crush hazards exist if standing under, or placing any body part under hoisted/suspended components. Never stand under hoisted/suspended components. Ensure appropriate lifting devices are used, and blocking is adequate to prevent the component from unexpectedly moving during transportation. Refer to SAFETY, WARNINGS, AND CAUTIONS before attempting to remove the operator's cab. Failure to stay out from under hoisted/suspended components can cause crush hazard resulting in serious injury or death.

Safety Preparations

- a. Check the weight capacities of all lifting devices.
- b. Check weight of planetary drive.
- c. Check weight of motor.
- d. Check weight of planetary drive and motor assembly.
- e. Use all personal protective equipment (PPE).

Installation

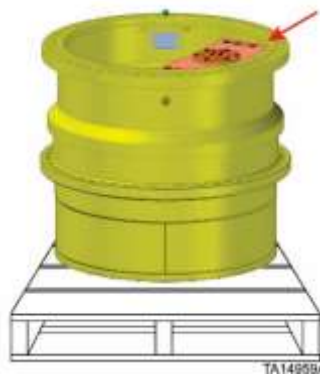

Inspect spindle for dirt or debris and lubricate primary gears with LPS-3 rust preventative/lubricant

Figure 30. Planetary drive positioned for installation of traction motor

- a. Hoist planetary drive with the inner-side up onto blocking placed to protect the cover structure from damage.
- b. Check inside spindle to be sure there is no dirt or debris before mounting motor.
- c. Lubricate primary gears with LPS-3 or equivalent rust preventative/lubricant.

- d. Check the threaded holes where the motor installs.
- Remove any oil, dirt, or debris in the holes.
 - The threads must be clean and dry.

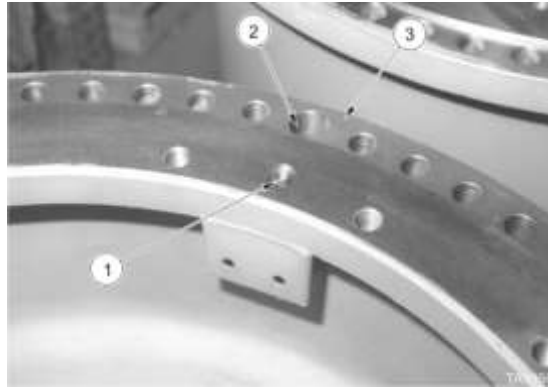

1) Vent tube, 2) dowel pin hole, 3) top of planetary drive 'a' countershaft pinion bore aligns with these items at top of drive

Figure 31. Location of top of planetary drive for installation of traction motor

- e. Note the position of the dowel pinhole and vent tube along the bolt flange of the planetary drive. This indicates the top of the drive as it is positioned in the axle and the correct alignment of the motor as it is hoisted onto the drive.
- f. Thoroughly clean the spindle vent tube and breather with LOCTITE 7056 or 7070 solvent (or equivalent - not oil based) and air dry.



Figure 32. Traction motor lifting fixture

- g. **Preferred Hoisting Method:** Install applicable hoisting fixtures with commercially available lifting clevis to each side of pole ring with 5/8-11 UNC-2B Grade 8 bolts on B40 motor, and 1-8 UNC-2B Grade 8 bolts on B60 motor.
- h. Check the threaded holes where the lifting fixture installs.
- Remove any oil, dirt, or debris in the holes.
 - The threads must be clean and dry.
- i. Hoist motor onto its side and place blocking for support.
- j. Lubricate teeth of motor pinion with LPS-3 or equivalent rust preventative\lubricant.

During assembly, the O-ring between the motor and the planetary drive is retained in position by use of silicone sealant.

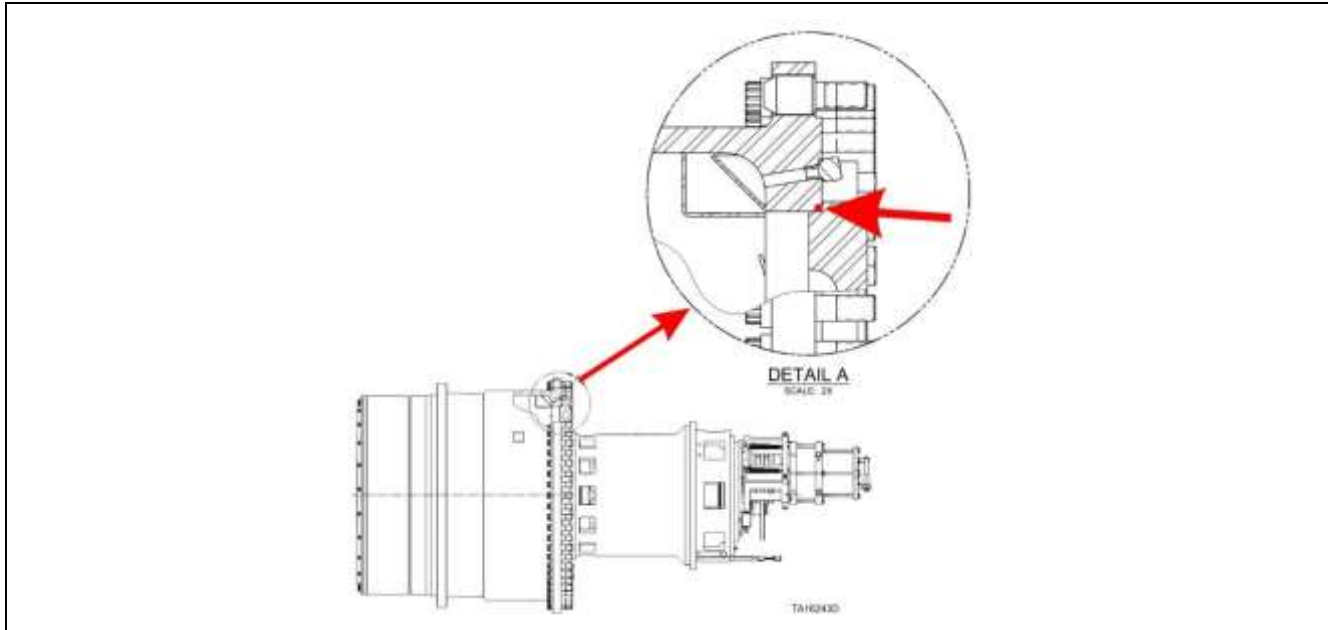

Figure 33. O-ring between planetary drive and drive motor location

The appropriate quantity and type of silicone sealant (P/N R4150226) must be ensured before being applied to motor-to-planetary drive O-ring. Due to regional availabilities of different silicone sealants, the following is the order of preference for silicone sealant:

- 1) Loctite 587
- 2) Permatex Ultra Blue
- 3) Loctite 598
- 4) Permatex Ultra Black

NOTICE

Use of the correct type and amount of silicone sealant is critical. The factory specifies R4150226 which is Loctite 587 Blue Silicone. Use of this brand and type of silicone is important since other types of silicone may not be oil proof and will degrade under constant exposure to oil.



Figure 34. R4150226 - Proper Type of Silicone for Motor and Driver Assembly

If excessive amounts of silicone sealant or the incorrect type of silicone sealant are applied during wheel motor and driver assembly, small amounts of sealant can protrude from the driver flange to motor adapter ring mating surface.

NOTICE

Do not cut the cartridge nozzle too close to the cartridge. This provides too much sealant too rapidly to make a small bead.



Figure 35. Cut sealant cartridge nozzle to make small bead of sealant

When the motor and driver are put into operation, excess sealant can become dislodged and potentially block critical lubrication oil flow paths such as the orifice in the endbell.

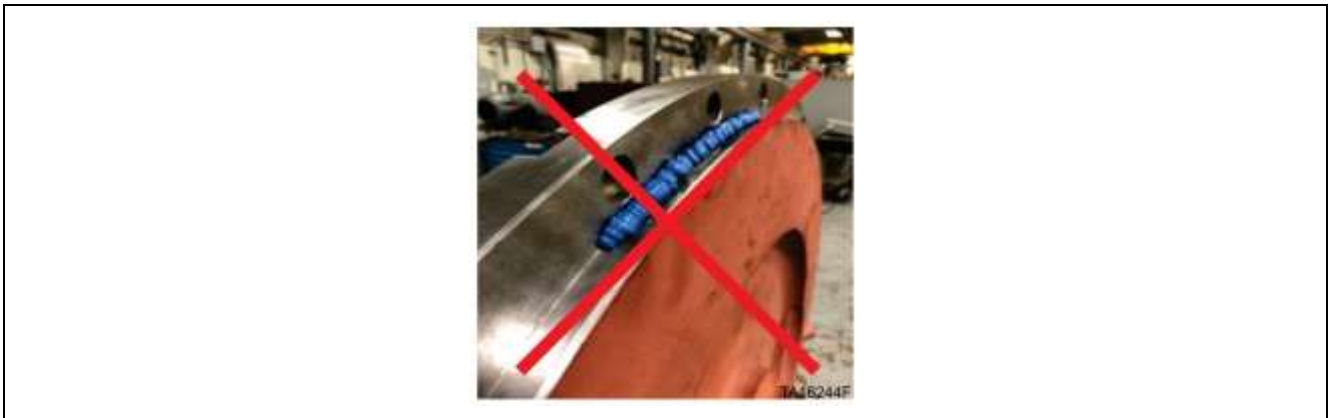

Figure 1 – Excess sealant can cause damage to the motor

NOTICE

If any of the motor bearing lubrication paths are blocked with dislodged sealant within the assembly, it can cause possible roller bearing failure, and in worst case, lead to motor failure.

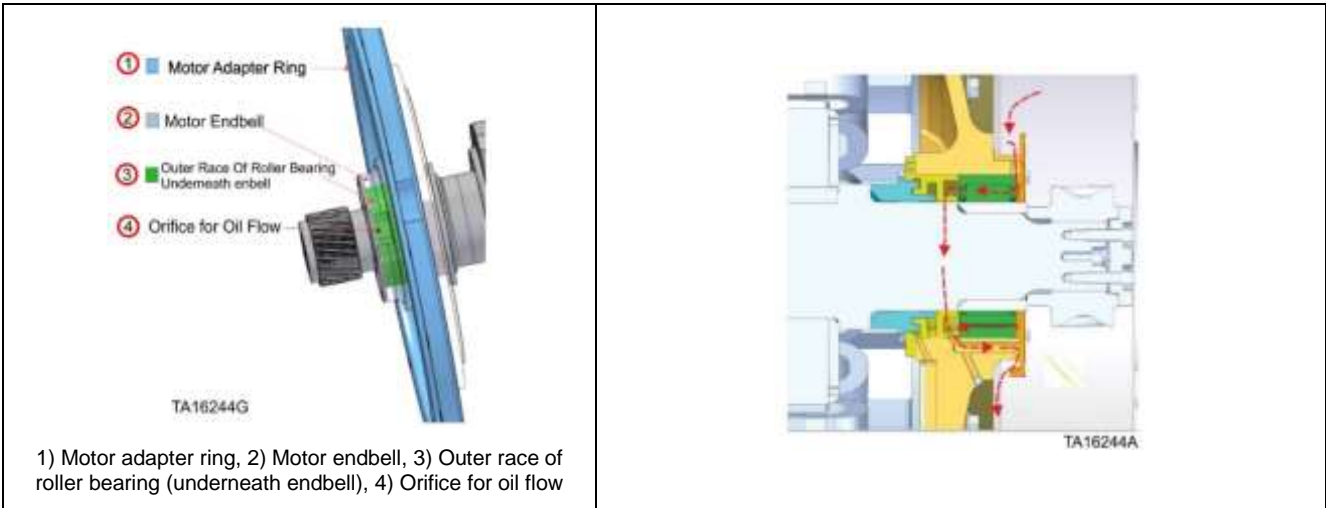

Figure 3 – Oil Flow Path to Roller Bearing

CAUTION

If the motor bearing fails due to lack of oil – the rotor will drop onto the stator. The contact between the rotor and stator will produce rapid heating of the stator laminations which may be detected by the RTD sensors in the coils. Indications of motor temperature rises can be identified by a yellow warning in LINC3 for excessive motor temperatures.



Figure 36. Examples of Yellow Warnings Associated with Motor Over-Temperature

A single mechanical motor failure can lead to reduced, but still functional, drive system capabilities. In the event of a wheel motor fault, Wheel Loader Operators should immediately stop the Wheel Loader in a safe location and condition until the wheel motor can be inspected.

- k. Apply a thin bead no larger than the size of the o-ring to the groove of the motor adapter face.



Figure 37. Correct application of silicone sealant

- l. Apply a thin coat to the external surfaces of the O-ring.

- Remove any visibly excess silicone.

- m. Install O-ring onto endbell.



Figure 38. O-ring installed with correct amount of sealant

- n. Position motor onto planetary drive. As the motor is positioned onto the planetary drive, turn the motor to mesh the motor pinion or coupling with first reduction primary gear (45, 51, and 57 planetary drives) or sun pinion coupling (35 planetary drive) and align capscrew holes on the motor with those on the drive.

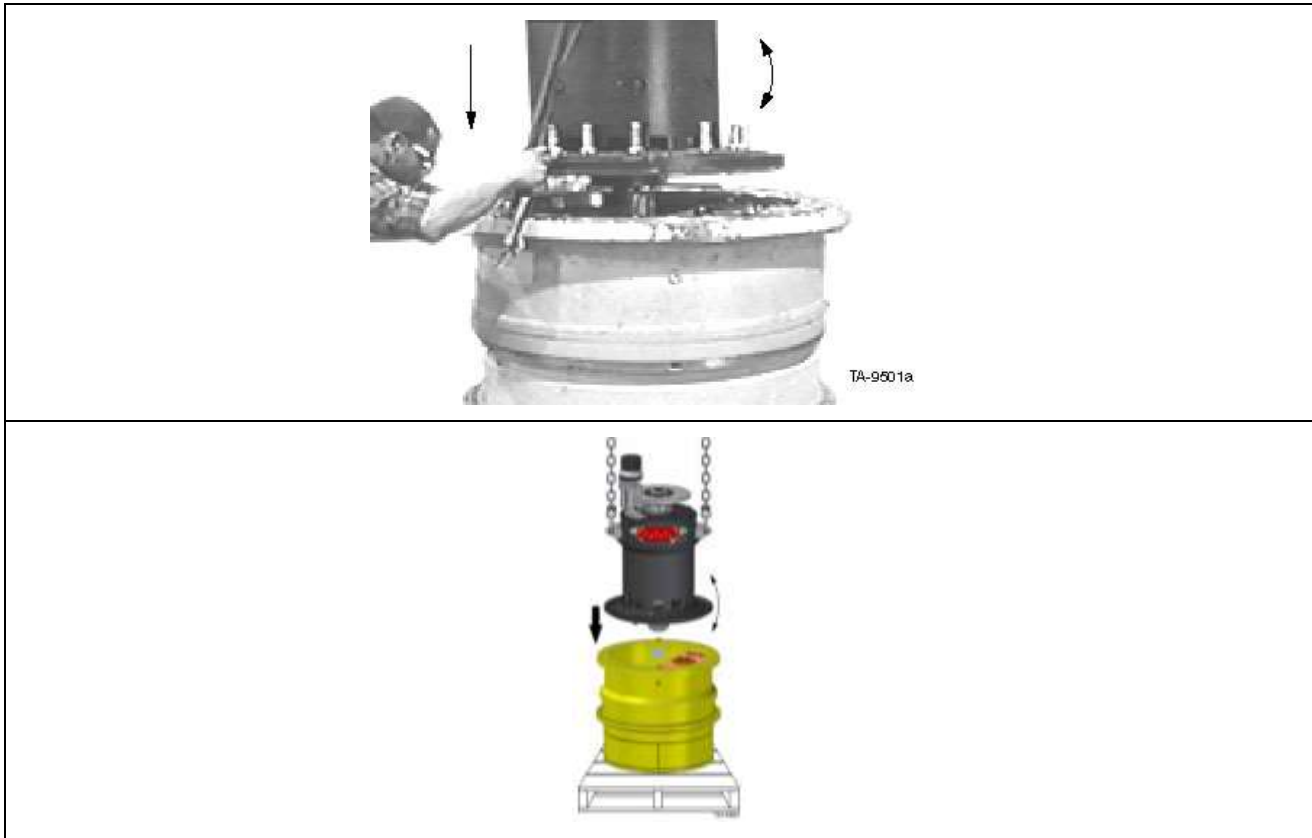

Figure 39. Positioning traction motor onto planetary drive

- o. Hoist motor to approximately 8 to 10" (203.2 mm to 254 mm) above the planetary drive. Place protective blocking between motor and planetary drive as shown.

NOTICE

Orientate the motor to the planetary drive so the motor leads will be at the bottom when the assembly is installed into the axle.



Figure 40. Blocking placed between planetary drive and traction motor for connection of oil return hose

- p. Connect the oil return hose, inside the primary gearbox, to the motor endbell.

CAUTION

Planetary drive models 57 and 51A2 have an internal planetary drive filtration hose connecting the planetary drive to the motor. On all planetary drives, ensure the hose is connected prior to joining the planetary drive to the motor. Failure to connect the hose can cause equipment damage.



Figure 41. Connection of oil return hose

- q. Apply sealant to all “motor-to-planetary drive” capscrew threads if required (see NOTICE below).

NOTICE

Models 51A2 and 51A3 planetary drives must have sealant on the “motor-to-planetary drive” capscrew threads to prevent leakage between the planetary drive and the motor. Model 57 planetary drive does not require thread sealant on the same threads. Model 57 planetary drive “motor-to-planetary drive” capscrews should be lubricated as normal before torquing.

Sealant must be one of the following (P/N R4150226):

- LOCTITE SI 587 BLUE
- LOCTITE SI 598 BLACK
- PERMATEX ULTRA BLUE
- PERMATEX ULTRA BLACK



Figure 42. Apply sealant to all motor-to-planetary drive capscrew threads

- r. Install capscrews. Torque capscrews to specifications per the “Capscrew and Bolt-Nut Torque Specifications”.



Figure 43. Install all motor-to-planetary drive capscrews

CAUTION

It is essential to use a calibrated torque wrench to properly torque the traction motor retaining fasteners per the “Capscrew and Bolt-Nut Torque Specifications”. Use of an air impact wrench alone to install the fasteners in lieu of a torque wrench could later result in component damage.

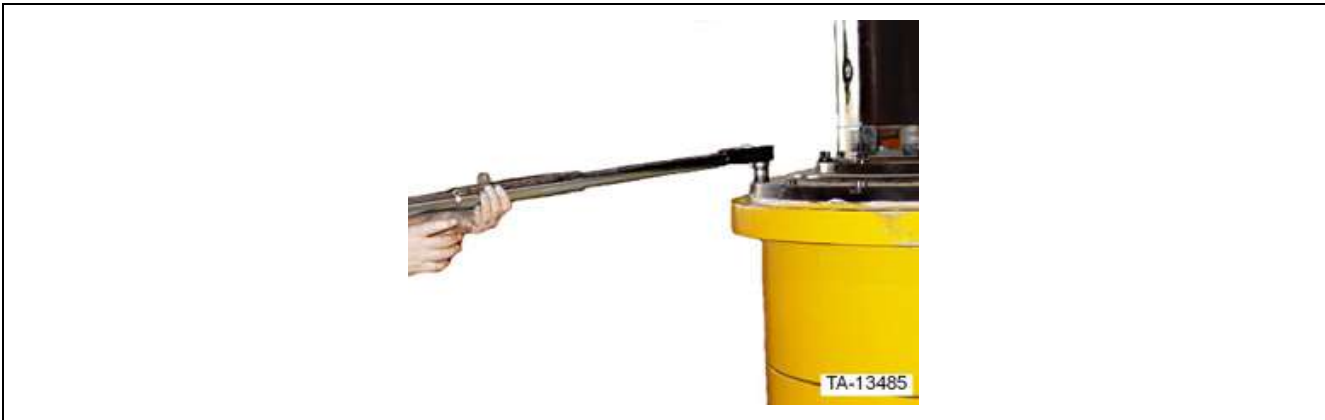

Figure 44. Torquing of traction motor retaining capscrews (typical torquing operation)

- s. Use a white paint pen to paint across the bolt heads and onto the planetary drive to indicate the bolts were torqued.

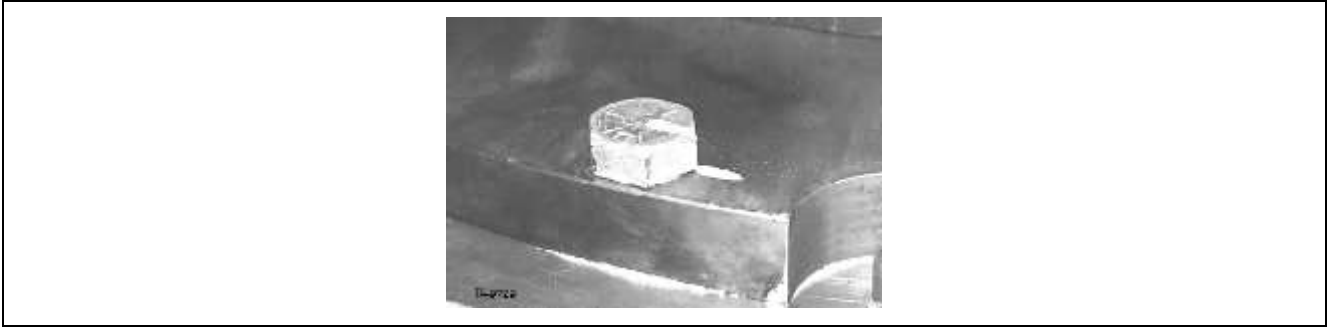

Figure 45. Marking traction motor retaining bolts to indicate torquing

- t. Install lifting eyes at 10 o'clock and 2 o'clock position of planetary drive spindle flange. Use shackles through lifting eyes and double-leg chain to attach to crane hoist. Slowly hoist the motor/planetary drive assembly. As it lifts, the assembly will tilt. Slowly hoist and "walk" the assembly to a horizontal position on plywood sheets on the floor. Block the assembly to prevent rolling and remove lifting eyes.

Installation of Traction Motor and Planetary Drive Assembly into Axle

Component Weights			
Component	Vehicle Type	Lb.	Kgs.
SR Motors	B40A (L-1350)	3,700	1,679
	B60 (L-1850-L-2350)	5,700	2,586
Planetary Drives	51A2 Planetary Drive (L-1350)	9,200	4,174
	57 Planetary Drive (L-1850-L-2350)	15,500	7,031
Tire & Wheel	L-1350	11,000	4,989
	L-1850	17,000	7,711
	L-2350	22,000	9,979
Motor, Planetary Drive and Brake Assembly	51A2 Planetary Drive, B40A Motor, Brake	13,000	6,532
	57 Planetary Drive, B60 Motor, Brake	21,200	9,617
	57 Planetary Drive, B60 Motor, Brake	21,200	9,617

Safety Preparations

Use the following procedure to isolate energy sources before performing any removal, replacement, or installation procedures described in this document.

WARNING

Crush hazards exist if the machine is started or moved while work processes are being performed on the machine. Place bucket flat and level on the ground. Place frame lock in the locked position and lock out the machine's starting capability before performing any work process. Follow all applicable lockout procedures and local rules and regulations for performing work processes. ANYONE performing inspections or service procedures to the machine should be familiar with ALL instructions and procedures contained in the machine's SERVICE MANUAL. Crush hazard could occur if the machine is started or moves while any type of work process is being conducted on the machine, resulting in serious injury or death.

- a. Stop the wheel loader on flat level ground.
- b. Move the frame lock to the locked position so that the frame cannot be steered.

WARNING

Crush hazards exist in machine pivot area and area between the tires. Do not enter these areas unless it is verified that the operator has control over the steering and that personnel locking the frame lock have good communication with the operator. Entering the pivot area and area between the tires while the machine is moving or pivoting (articulating) could cause crush hazards resulting in serious injury or death.

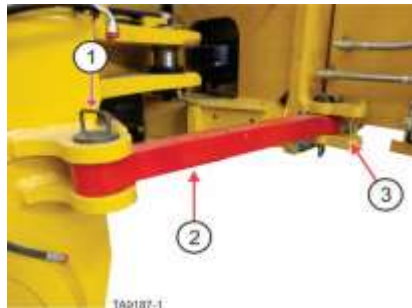

- 1) Retaining pin for locked position, 2) Frame lock - shown in locked position,
- 3) Retaining pin bracket for un-locked position

Frame lock in locked position

- c. Place wheel chocks in front and behind each wheel.
- d. Set bucket flat and level on the ground.
- e. Set the parking brakes.
- f. Shut off the engine.

⚠ WARNING

Crush, shock, or other hazards exist if stored energy is not removed or isolated prior to working on the machine. Stored energy (hydraulic, electrical, pneumatic, mechanical, etc.) may be present if not isolated or released prior to working on the machine. Do not work on the machine without removing this stored energy (suspended loads, electrical power, air pressure, etc.). Risk of crushing, shock, or other physical injury exists if stored energy is not removed or isolated prior to working on the machine which could result in serious injury or death.

- g. Turn the battery and engine isolation switches to the off position and install locks on the battery isolation switch.



GEN 2 Battery Isolation Box – Battery isolation switch in OFF position with locks in place

NOTICE

The GEN 2 battery and engine starter isolation box is shown in this document. GEN 1 machines will have a different type of switch and box. The lock out/tag out requirements are the same.

- h. Release the air from the hydraulic reservoir by using the hydraulic reservoir air valve (ball valve) on top of the reservoir. The supply line from main air system will be blocked and reservoir air will vent out the hose that runs down the outside of the hydraulic reservoir.
- Turn the handle to the up position as shown

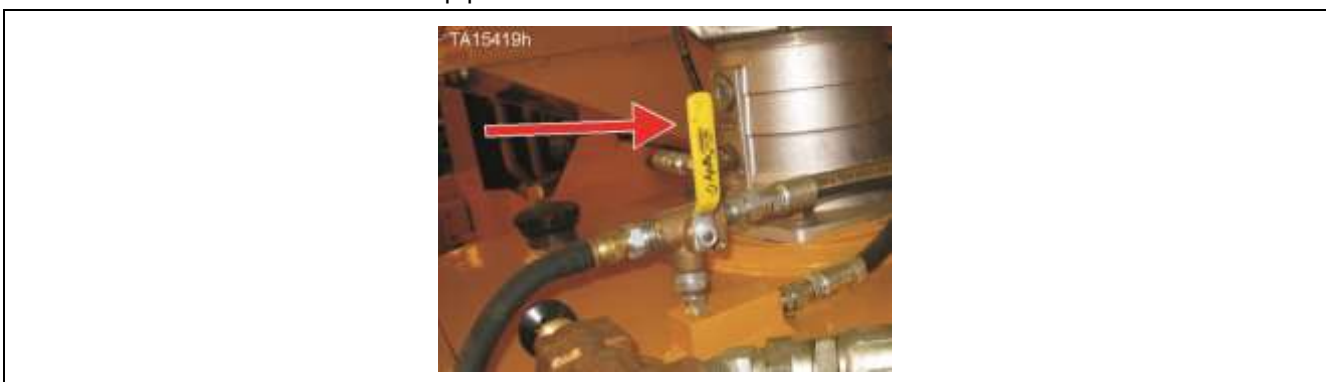

Figure 46. Hydraulic reservoir air valve handle UP

- i. Release the air from the various air storage reservoirs by opening all of the air bleed valves.

Three valves on right side of rear frame under hydraulic reservoir

One valve on right side of front frame near hoist cylinder ball cap



Open air reservoir bleed valves

WARNING

Crush hazards exist if all personnel are not cleared from the bucket and lift arm area before using the hydraulic hoist and bucket hydraulic pressure bleed down valves to relieve pressure from the hoist and bucket circuit. Clear all personnel from the area around the bucket and lift arms before operating hydraulic hoist and bucket hydraulic pressure bleed down valves. Using the hydraulic bleed down valves could result in some movement of the lift arms and bucket which could cause a crush hazard resulting serious injury or death.

- j. Use the hydraulic pressure bleed down valves located in the front frame underneath the Husco valves to bleed any stored pressure in the hoist and bucket cylinders.
- k. Turn each valve slowly counterclockwise as shown below and allow the pressure to bleed down.
- l. Open the valve completely and leave it open during this procedure.

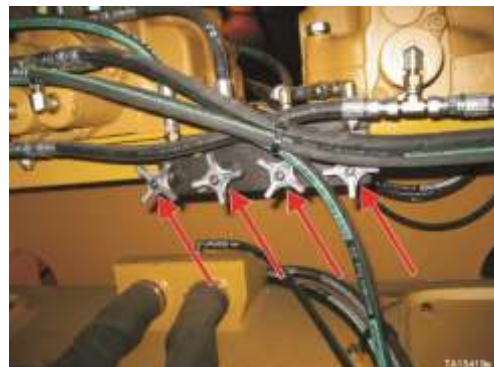

Figure 47. Pressure bleed down valves

Converter Bus Voltage

WARNING



Risk of fatal electrical shock or injury by contact in the electrical cabinet is possible if the engine is running, the LINCOS software indicates voltage on the bus, or the red bus LED's in the electrical cabinet are illuminated. All Generation II SR equipment has the ability to produce voltage at low throttle. Even with the engine off, there may be a residual of 12-15VDC on the bus. Do not enter the electrical cabinet or touch any components in the electrical cabinet without performing the Bus Discharge Verification Procedure. Failure to do so may result in fatal electrical shock or other injury.

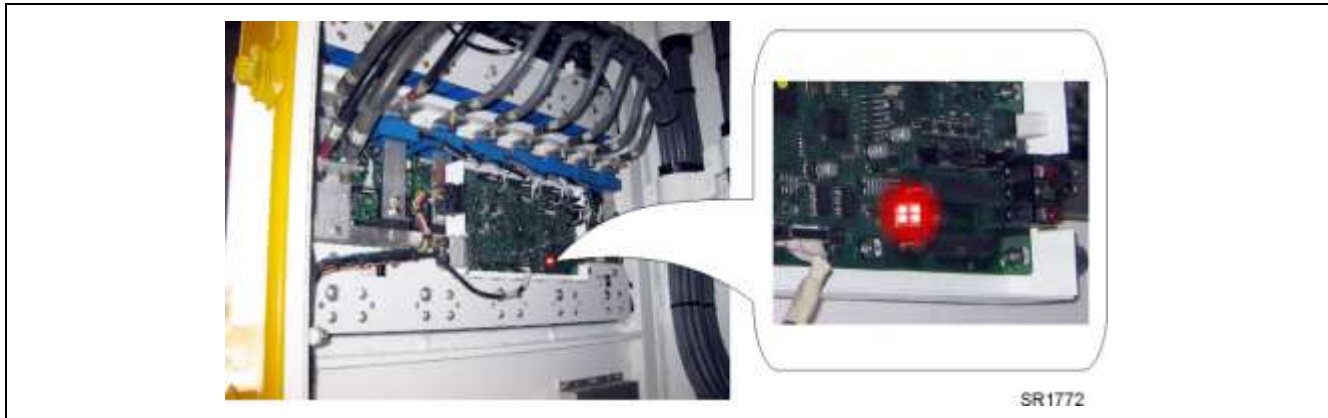

Figure 48. Converter assembly bus LED's

There are three different methods that are combined to verify when it is safe to enter the electrical cabinet.

1. LINCOS II display in cab
2. visual indication in electrical cabinet
3. physical measurement

All these steps are required to ensure that the system is properly discharged.

In Cab Verification Using LINCS II Display

1. Make sure that the LINCS II system is booted (key switch ON) with the engine NOT running and the park brake SET.
2. As shown in the figure below, on the touch panel in the dash, press the Main Menu button in the lower left corner, then select Data Logging then Logging/Monitoring.

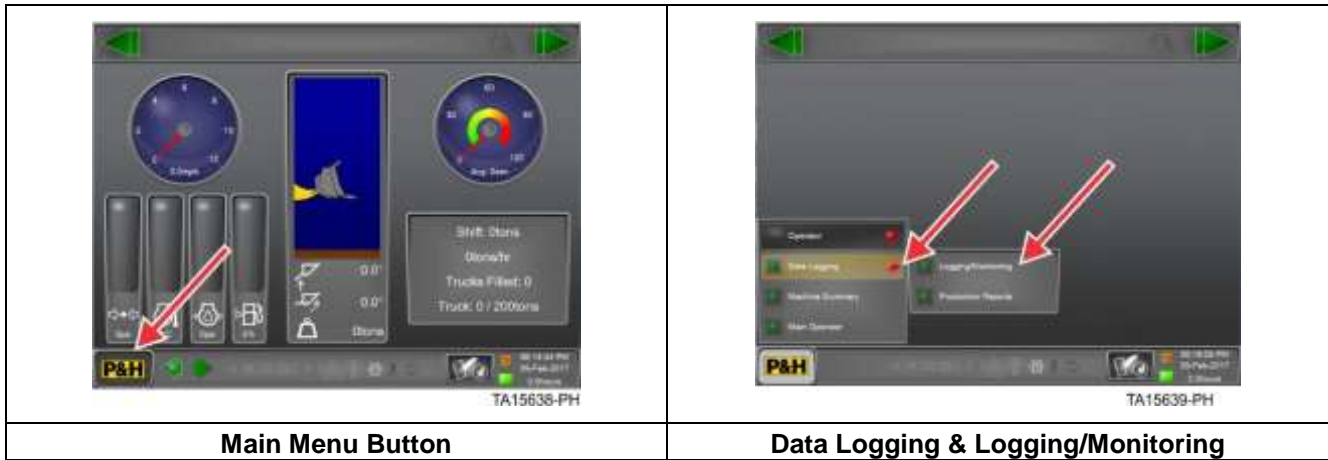

LINCS logging/monitoring menu access

3. Select the Trash Can icon and the select the Check Mark to clear any selection on the right hand side of the screen (if applicable).



Remove channels

4. Scroll down the left hand list until Drive Fuses is displayed.



Left hand scroll

5. Drag the Drive Fuses category to the right hand side of the screen, all of the bus voltage channels should now be visible.



Bus voltage indication

6. Verify bus voltage is less than 24VDC.

NOTICE

Should any voltage (greater than 24VDC) be present on any of the DC busses, allow the system to discharge for a period of no less than 10 minutes. Re-test the bus voltages prior to continuing.

7. Turn the key switch to the OFF position and proceed to the next step in the verification process.

Verification by Visual Indication

Following the verification by LINC'S II software, the next step is to verify the existence of bus voltage by the array of four LED indicators located on the main SR control board on each converter assembly.

To conduct this test, ensure that:

- The 24VDC power is isolated at the battery disconnect (turned off and locked out) per site requirements.

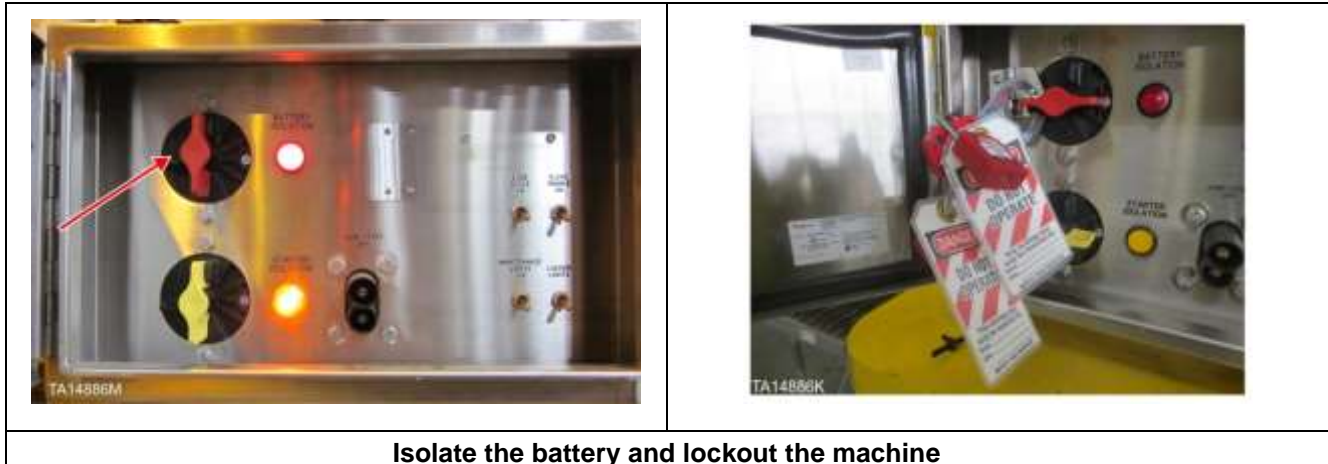

Isolate the battery and lockout the machine

Figure 49. Isolation and control switch assembly

- The SR electrical converter cabinet door should now be opened.
- DO NOT enter the cabinet at this time.

View the LED arrays on each of the converter assemblies and verify the LED's are not illuminated. The LED's will be illuminated when a potential of greater than approximately 35VDC is present on the DC bus connections on the converter assemblies. The light intensity varies with voltage and a greater intensity indicates a higher bus voltage.

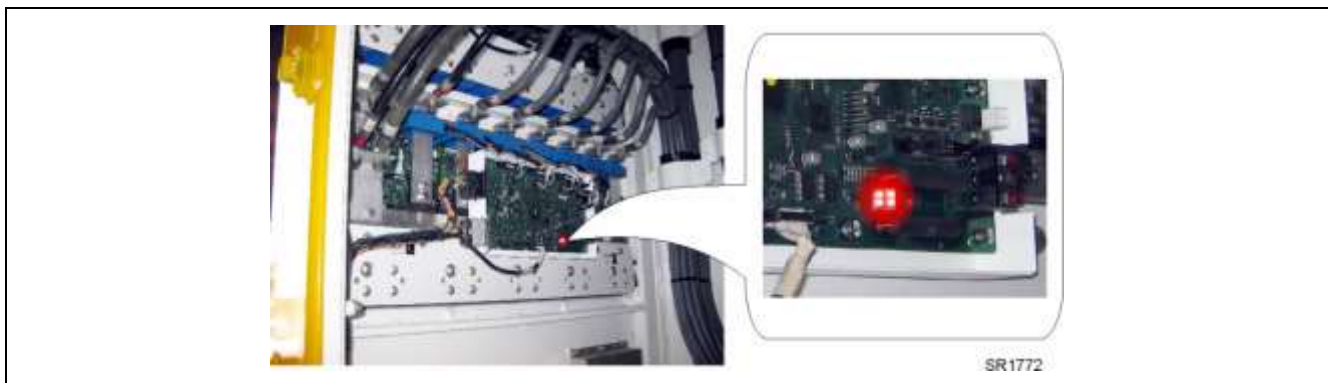

Figure 50. Bus voltage LED array on SR control board

Verification by Physical Measurement Main Bus Bars

Once the visual indicators have been verified, the bus voltage should be physically measured. The bus voltage should be fully discharged based on the previous checks.

- a. Measure between the positive and negative bus bars using a voltmeter rated for 1000V. The potential voltage on a bus that has not discharged could be over 700VDC. A properly discharged bus should be less than 24VDC as verified by the completion of LINCS system verification.

WARNING

High voltage may be present. Risk of shock or equipment damage by use of an improperly rated meter is possible. Use a CAT III 1000V rated volt meter to take voltage readings.

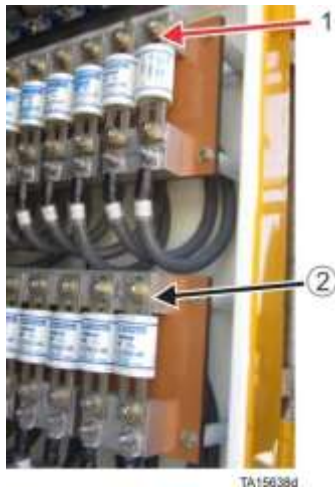

1) Positive bus bar, 2) Negative bus bar

Figure 51. Main bus bars

Converter Assembly Bus Connections

The final point of verification is the bus connections to each individual converter assembly. The bus voltage can be measured at the two bus tabs located adjacent to the electrical converter cabinet door.

NOTICE

The converter assemblies on the rear of the cabinet are inverted in comparison to those mounted on the front. Similarly, the positive and negative bus connections will be inverted.

Connect a voltmeter across the two bus connection points. Bus voltage should be less than 24VDC following the completion of the previous checks. Once the check has been completed, the entire drive system has been verified as discharged.



1) Positive bus bar, 2) Negative bus bar

Figure 52. Converter assembly bus connections (rear of cabinet)



1) Positive bus bar, 2) Negative bus bar

Figure 53. Converter assembly bus connections (front of cabinet)

Installation

- a. Install the applicable lifting device on planetary drive as it was positioned for removal.
- b. Attach crane to the lifting device with an adequate lifting clevis and support the drive.



Figure 54. Hoisting assembly into axle

- c. Hoist traction motor and planetary drive assembly into axle. Keep planetary drive and traction motor in a horizontal position during installation.

CAUTION

Pinch point hazards exist when routing the hoses inside the axle. Never place any body part against a solid, un-moveable component surface when the motor is being installed inside the axle. Inspect the inside axle area for pinch points before installing the motor and planetary drive assembly. Close attention is required to avoid potential body pinch points when routing hoses inside the axle during planetary drive/motor installation. Direct communication between the crane operator and installer and expert control of the crane are required. Failure to inspect inside the axle for pinch points, and to have good communications between the crane operator and the installer can result in pinch points resulting in personal injury.

CAUTION

As the assembly is hoisted into the axle, a technician should monitor the electrical lines and air hoses inside the axle to ensure none are damaged.

- d. Attach planetary drive oil filtration system lines to the motor endbell.
- e. Secure planetary drive to axle with capscrews. Torque capscrews to specifications, per the “Capscrew and Bolt-Nut Torque Specifications”.
- f. Check planetary drive to be sure it has the correct oil level. Refer to” PLANETARY DRIVE MAINTENANCE AND ROTATION” in Section 2 of Service Manual for filling procedures.

WARNING

Electrical shock hazards exist inside the axle if touching electrical connections inside the axle without verifying the absence of bus voltage. NEVER touch electrical lead connections unless the machine’s electrical system has been turned off and locked out, and the absence of bus voltage is verified. Contact with energized terminals inside the axle could cause electrical shock resulting in serious injury or death.

- g. Connect electrical leads to terminal block as tagged.
- h. Connect air lines to brake canister.

- i. Check brake for proper operation and clearances (refer to section 5.2).
- j. Install tire and wheel. Refer to "WHEEL AND TIRE INSTALLATION" in Section 3 of Service Manual for installation procedures. Torque to specifications per the "Capscrew and Bolt-Nut Torque Specifications".
- k. Inflate tire to pressure listed in TIRE INFLATION AND DEFLATION in Section 3 of Service Manual. Follow safety instructions for tire inflation as outlined in TIRE AND RIM SAFETY HINTS in Section 3 of Service Manual.
- l. Install axle access covers.
- m. Close Compressed Air System pressure release valves.
- n. Lower Loader to the ground and remove wheel chocks.
- o. Move frame lock to unlocked position.

NOTICE

Verify torque on wheel attaching capscrews after the first 2, 6, 14, and 100 hours of operation and every 500 hours thereafter.

Servicing Requirements after Planetary Drive Repair or Replacement

A new or rebuilt planetary drive, or one in which components have been replaced, must have the planetary drive filtration system strainer cleaned and the filter replaced after the first 500 hours and every 2000 hours thereafter.

NOTICE

Refer to **PLANETARY DRIVE PREVENTIVE MAINTENANCE** in Section 02-01-06”PM Planetary Drive Maintenance and Rotation “-in the Service Manual for instructions on draining, flushing, and refilling the planetary drive and servicing the planetary drive oil filtration system (if present).

Daily	Initial 500 hours (break-in period)	Every 500 hours	Every 2,000 hours	Every 10,000 hours	Every 20,000 hours
<ul style="list-style-type: none"> Check for leaks inside and outside of wheel (including planetary drive filtration system filters, hoses and fittings). 	<ul style="list-style-type: none"> Clean strainers. Replace filters 	<ul style="list-style-type: none"> Collect oil samples for analysis 	<ul style="list-style-type: none"> Clean strainers. Replace filters Verify condition of oil – drain, flush and replace when oil analysis indicates the need*. 	<p>Machines with Model 51A2/57</p> <ul style="list-style-type: none"> Rotate per rotation patterns shown on illustration PLANETARY DRIVE ROTATION PATTERNS*. 	<p>Machines with Model 51A2</p> <ul style="list-style-type: none"> Drain Remove cover structure Inspect counter-shaft gears and middle pinion. Remove drive motor Inspect primary gears Rotate. <p>Machines with Model 57</p> <ul style="list-style-type: none"> Remove inspection plate Inspect middle pinion and countershaft gears Rotate

NOTICE

*Field research indicates synthetic oil can often be run in excess of 5000 hours before draining and flushing is required. Due to limited accessibility of primary gear side drain plug on models-with Model 57 planetary drive, draining and flushing is recommended at the 10,000-hour rotation interval, if the need to drain and flush is indicated by oil analysis.

Table 1. Service reference chart for planetary drive models 51A2, and 57

This Page Intentionally Left Blank

Planetary Drive (Driver) General Lubrication Requirements

Lubricants used in Komatsu wheel loader planetary drives (drivers) must be synthetic gear oils with EP additive packages.

Component	Model and Size		Capacity (each)		Lubricant
Planetary Drive	L-1350	51A2	36 gallons	135 liters	See following chart for approved lubricant
	L-1850	57	40 gallons	151 liters	
	L-2350	57	40 gallons	151 liters	

Table 2. Planetary drive capacities

ISO Viscosity Grade

ISO viscosity grade of lubricant must be as follows for individual drivers: (see exception in endnote #3)

Driver	Conditions	
	Standard	Arctic*
51A/51A2/51B	460	220
57	460	220

* Arctic conditions are defined as an ambient temperature consistently below 0°F (-18°C).

Table 3. Planetary drive lubricant viscosity grade

Lubricant Properties

Properties of lubricant must comply with the following table: (see exception in endnote #3)

Property	Value	
	ISO 220 Grade	ISO 460 Grade
Kinematic Viscosity at 40°C (cSt)	198-242	414-506
Kinematic Viscosity at 100°C, minimum (cSt)	25	45
Viscosity Index, minimum	150	
Pour point, maximum ¹	-36°C	
4-Ball EP Test (ASTM D2783): Weld load (kg) ²	250	
Timken OK Load (lb.) ²	60	
FZG Gear Scuffing (ISO 14635-1) Pass Stage	12 or greater	
Copper Corrosion (ASTM D130 – 3 hrs@100°C)	1B	
Foaming (ASTM D892, Sequence I, II, III) maximum values (ml/ml)	5/0, 10/0, 5/0	
Rust protection (ASTM D665 – Method B)	Pass	

Endnotes

- ¹ Lubricant with higher pour point may be used, provided the pour point is 5°C lower than the minimum ambient temperature.
- ² Oil manufacturer may report either 4-Ball EP test or Timken OK load. However, if both results are reported, fluid must meet requirements of both tests.
- ³ **Mobil SHC Gear OH** is available in a lowest viscosity grade of 320. However, this upgraded lubricant will outperform the older-technology MobilGear SHC 220 in arctic temperatures due to its higher viscosity index and lower pour point.

Table 4. Planetary drive lubrication properties

Motors with Labyrinth Seal

B40A and B60 motors have labyrinth seals. The following is intended to only show a typical labyrinth seal set-up and possible problems caused by overfilling a typical planetary drive with a labyrinth seal.

NOTICE

The following illustrations show a typical 45 planetary drive set-up with a labyrinth seal.

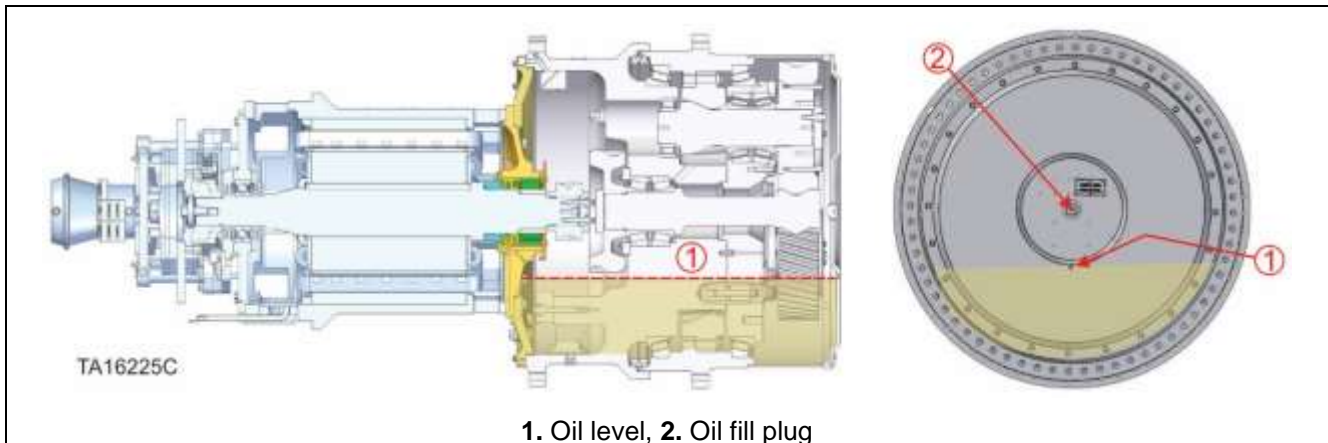

Figure 55. Verify correct lubricant level (45 planetary drive shown)

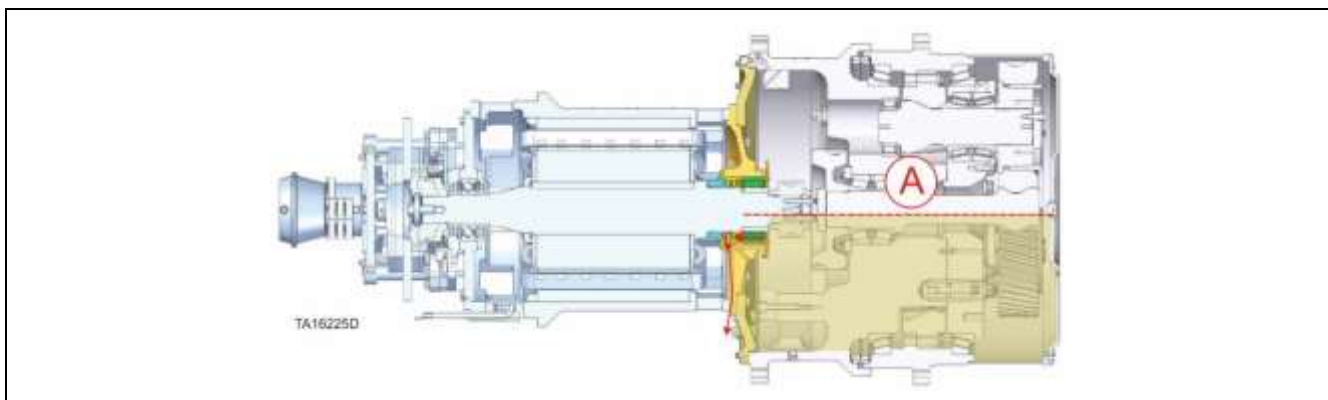

Figure 56. Incorrect Oil level (too high) (45 planetary drive shown)

NOTICE

Oil level above labyrinth seal will seep through labyrinth when motor not rotating

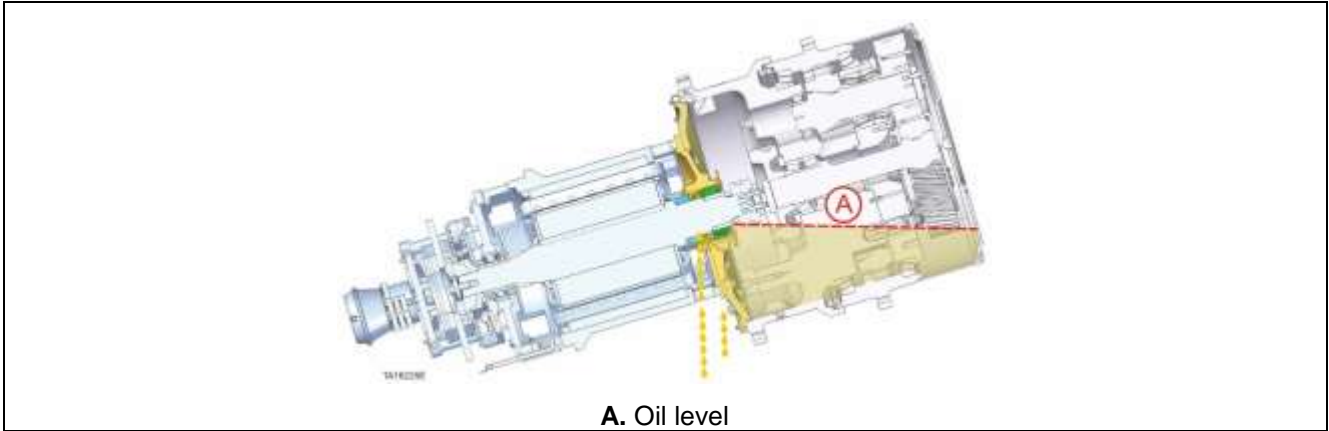

Figure 57. Machine stationary on very steep side slope with oil over labyrinth seal (45 planetary drive shown)

NOTICE

When Oil is over labyrinth seal, it can leak through the stationary seal and leak oil into axle.

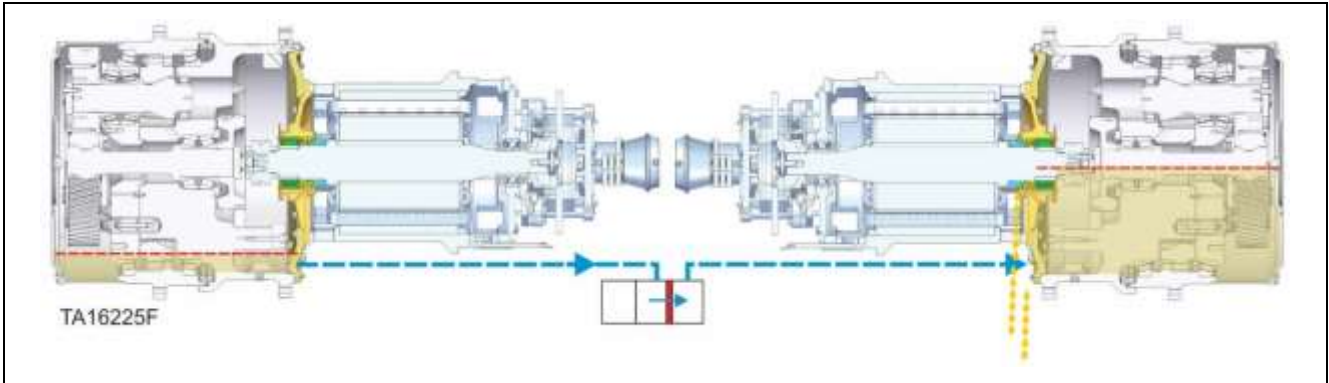

Figure 58. Defective filtration pump (45 planetary drive shown)

NOTICE

Defective filtration pump can cause overfilled driver on one side and low oil level on the other side.

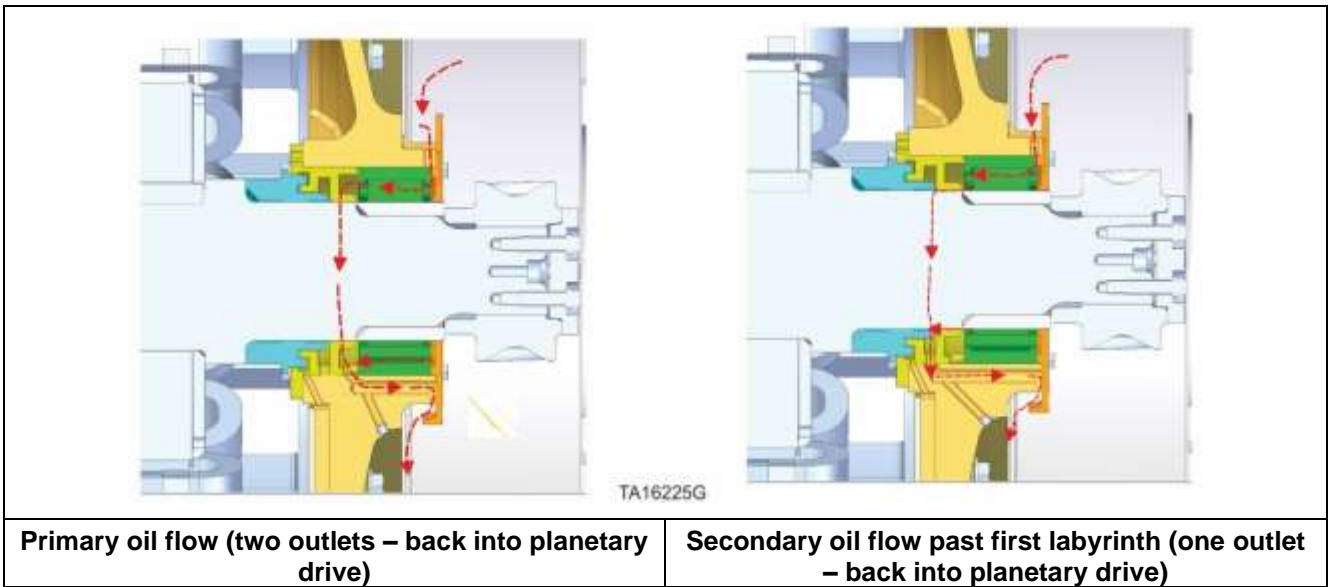

Figure 59. Normal oil movement through labyrinth (45 planetary drive shown)

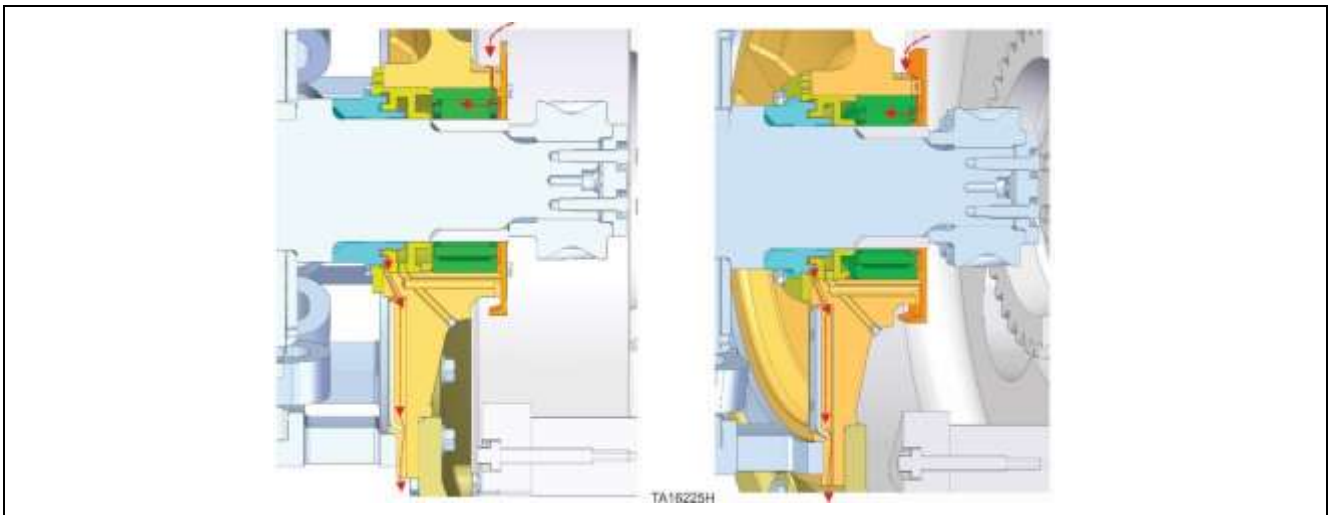

Figure 60. One outlet – on outside of endbell (45 planetary drive shown)

NOTICE

Oil seepage that gets past first and second labyrinth typically only occurs when stopped on a slope or during shipping.

Capscrew and Bolt-Nut Torque Specifications

There are some exceptions to the torques provided on the following pages. Reduced torques are specified in the planetary drive rebuild manual, for the capscrews holding the planetary drive covers, due to a copper sealing washer under the head of the capscrew.

The torque specifications on this chart apply only to Grade 8 bolts, black or gold colored, and 12PT black-colored alloy steel capscrews. 12PT capscrews with gold-colored zinc chromate plating are excluded from these specifications and the zinc chromate 12PT capscrews should not be used on loaders or dozers. (except for planetary drive covers)

These torque values are for normal routine operations. If doing component rebuilds or any other abnormal machine component assembly/disassembly, please contact the factory for these values for specific instances.

 <p style="text-align: right; font-size: small;">TA15358A</p>	 <p style="text-align: right; font-size: small;">TA15358B</p>	 <p style="text-align: left; font-size: small;">TA15356-1</p>
<p style="text-align: center;">Does not apply X</p>	<p style="text-align: center;">12PT Alloy Capscrew ✓</p>	<p style="text-align: center;">Grade 8 Bolt ✓</p>

NOTICE

Please note the additional tables for exceptions to the torque values for items such as Lift Arm Ballcaps, Super Nuts and steering pin bolts with drilled grease passages.

Please direct any questions to Komatsu Product Support.

Capscrew and Bolt-Nut Torque Specifications Chart

Standard SAE G8 and Alloy Steel and Hex Socket Capscrews

Size	Thread	GRADE 8 Fasteners		Alloy Steel 12PT. and Hex Socket Capscrews	
		USA Units lb-ft	Metric Units N-m	USA Units lb-ft	Metric Units N-m
		**Lubed	**Lubed	**Lubed	**Lubed
1/4 (0.25)	20 UNC	9	13	12	16
	28 UNF	10	14	14	19
5/16 (0.3125)	18 UNC	18	25	24	33
	24 UNF	20	27	27	37
3/8 (0.375)	16 UNC	33	45	45	61
	24 UNF	37	50	50	68
7/16 (0.4375) (* See Note below)	14 UNC	52	71	70	95
	20 UNF	58	79	79	107
1/2 (0.5) (* See Note below)	13 UNC	80	109	108	146
	20 UNF	90	122	122	165
5/8 (0.625)	11 UNC	159	216	203	275
	18 UNF	180	244	230	312
3/4 (0.75)	10 UNC	282	383	361	490
	16 UNF	315	427	403	546
1 (1.0) (***) See Note below)	8 UNC	682	925	872	1182
	14 UNS	764	1,036	977	1325
1-1/8 (1.125)	7 UNC	966	1310	1235	1674
	12 UNF	1083	1468	1385	1878
1-1/4 (1.25) (***) See Note below)	7 UNC	1,363	1,848	1744	2365
	12 UNF	1,509	2,046	1930	2617
1-1/2 (1.5)	6 UNC	2,371	3,215	3033	4113
	12 UNF	2,668	3,618	3413	4628
* See Special Torque Specifications for ROPS super nut.			*** This bolt is UNS (with 14 threads per inch), it is NOT UNF. It is a unique thread count bolt.		
** See page 4 for specifications for "LUBED" – engine oil on threads and shoulder.			**** See Special Torque Specifications for loader lift arms and 1350/1850/2350 steering pins.		
*** See Special Torque Specifications for 950/1150 steering pins.					

Standard Metric Bolts and Grades (SAE J1701M)

Size (mm)	Pitch (mm)	Property Class 8.8		Property Class 10.9		Property Class 12.9	
		USA Units lb-ft	Metric Units N-m	USA Units lb-ft	Metric Units N-m	USA Units lb-ft	Metric Units N-m
		** Lubed	** Lubed	** Lubed	** Lubed	** Lubed	** Lubed
6	1.00	6	8	8	11	10	13
7	1.00	10	13	14	19	16	22
8	1.25	14	19	20	27	24	32
10	1.50	28	38	40	54	47	63
12	1.75	49	66	70	94	81	110
14	2.00	77	105	111	150	130	176
16	2.00	121	164	173	235	202	274
18	2.50	167	226	239	324	279	378
20	2.50	244	331	337	458	394	535
24	3.00	422	572	584	791	682	925

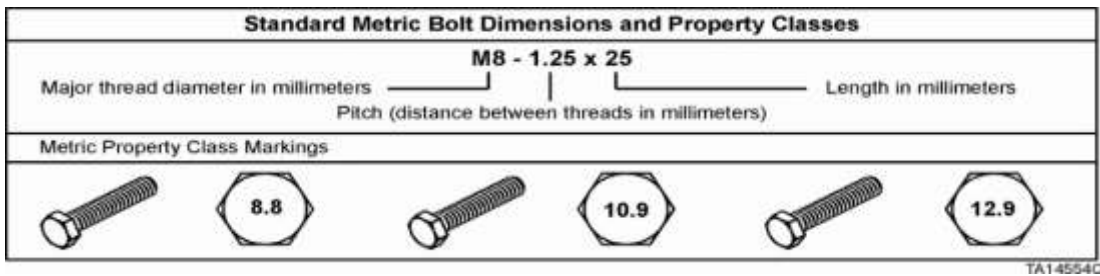

Capscrew and Bolt-Nut Torque Specifications

Special Torque Specifications**Alloy Steel 12PT. Capscrew for Wheel Loader Lift Arm Ballcaps**

Size	Type	Thread	USA Units lb-ft	Metric Units N-m	Application
			**Lubed	**Lubed	
1-1/4 (1.250)	12PT. capscrew F-C on head	7 UNC	1900	2577	LHD, L-950, L-1150, L-1350, L-1850, and L-2350 (Lift arm ball caps only)
1-1/4 (1.250)	12PT. capscrew B-7 on head	12 UNF	1320	1790	L-1000-L-1100 (Lift arm ball caps only)

Steering Pins (Hex Head Bolt)

Size	Type	Thread	USA Units lb-ft	Metric Lubed N-m	Application
			** Lubed	** Lubed	
1 (1.0)	Bolt (drilled center)	8UNC	425	576	LHD, L-950, D-950, L-1150 (Steering Pins)
1-1/4 (1.250)	Bolt (drilled center)	7UNC	850	1152	L-1350, L-1850, L-2350 (Steering Pins)





Aluminum 12pt. Capscrews used for Motor Pinion Balancing

Size	Type	Thread	USA Units (lb-ft)		Metric Units (N-m)	
			Dry	**Lubed	Dry	**Lubed
3/4 (0.75)	Aluminum	16 UNF	114	86	155	117
3/4 (0.75)	Aluminum 2024-T4	16 UNF	150	113	203	153
15/16 (.9375)	Aluminum 6061 T6	12 NF	217	163	294	221
15/16 (.9375)	Aluminum 2024-T4	12 NF (2 START)	285	214	387	290

2-Thread (2-Start) Steel 12PT. Capscrews

Size	Type	Thread	USA Units lb-ft	Metric Units N-m
			** Lubed	** Lubed
3/8 (.3750)	12PT.	24 NF	25	34
9/16 (.5625)	12PT.	18 NF	87	119
15/16 (.9375)	12PT.	14 NF	428	584
1-5/16 (1.325)	12PT.	12 NF	1216	1660

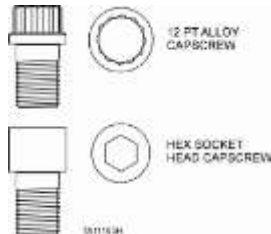
Bolt and Capscrew Markings on Head

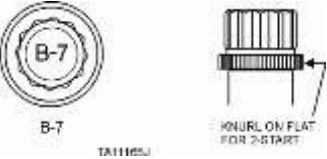
<p>GRADE 5 BOLTS & CAPSCREWS (*TORQUE TO 70% OF GRADE 8 VALUES)</p>  <p>NOTCH ON GRADE 5 12 POINT CAPSCREW HEAD</p> <p>TAPER HEAD - OR - FLAT HEAD</p> <p>(OLD LeTourneau manufactured capscrews)</p>	<p>GRADE 8 MARKINGS ON BOLT HEAD</p> 	 <p>12 PT ALLOY CAPSCREW</p> <p>HEX SOCKET HEAD CAPSCREW</p>	
<p>Typical Markings on Alloy Capscrew Heads</p>		<p>Typical B-7, 2-Start</p>	
 <p>ALL PRO FERRY DARLING CARDINAL SOCKET HEAD</p>		 <p>B-7</p> <p>KNURL ON FLAT FOR 2-START</p>	
<p>** See "Key Items" for specifications for "LUBED" – engine oil on threads and shoulder.</p>			

Capscrew and Bolt-Nut Torque Specifications

Key Items

- “LUBED” is defined as having the threads and under the head lubricated with engine oil. Engine oil is defined as SAE 30 or 40 weight oil, including multi viscosity grades 5W-30 through 15W-40. No other lubricant (such as anti-seize, MolyKote, copper coat, grease, etc.) is permitted unless specifically called out in a Komatsu procedure.

****LUBED = Lubricated with engine oil on threads and under head**
 (SAE 30 or 40 weight oil, including multi viscosity grades 5W-30 through 15W-40)



NOTE: No other lubricant (such as anti-seize, never seize, MolyKote, copper coat, grease, etc.) is permitted unless specifically called out in a Komatsu procedure.

- All capscrews and bolts should be started by hand until a minimum of three (3) threads are engaged prior to any air impact equipment being used.
- If a procedure in a Rebuild Manual, Repair and Overhaul or Operating and Service Manual calls for the use of Loctite® threadlocker on the threads, the torque specification for “lubed” should be used. The threads on both the fastener and mating part should be thoroughly cleaned with a proper solvent prior to use of Loctite®. The Loctite® thread sealant should only be used on the threads - not the head.
- Certain applications in components such as drivers or lift arm ball caps may specify a FERRY brand of capscrew. Use only FERRY brand capscrews in these applications.
- Komatsu, recommends that any old 12PT. Komatsu-fabricated (fabrication was stopped many years ago) capscrew (refer to illustration under BOLT AND CAPSCREW MARKINGS ON HEAD) be replaced at the time of repair with alloy capscrews. If new capscrews are not available, then the Komatsu-fabricated capscrews should only be torqued to Grade 5 specifications (70% of Grade 8 value - lubed).
- The torque specifications on the charts on page 2 only apply to Grade 8 bolts, metric bolts and 12PT. black-colored alloy steel capscrews. Capscrews with gold-colored zinc chromate plating are excluded from these specifications and these capscrews should not be used on loaders or dozers except for driver covers.



Does not apply X



12PT Alloy Capscrew ✓



Grade 8 Bolt ✓

- **CLEANING:** It is mandatory to remove all paint, rust and debris from all mating surfaces, surfaces under the head of the bolt or capscrew and threads prior to installation and torquing of all bolts and capscrews.



Arrow indicates location to be cleaned



Cleaning paint and rust prior to torquing

This Page Intentionally Left Blank